

INSTALLATION INSTRUCTIONS

4 PANEL SLIDING GLASS DOOR

NARROWLINE | GRANDLINE

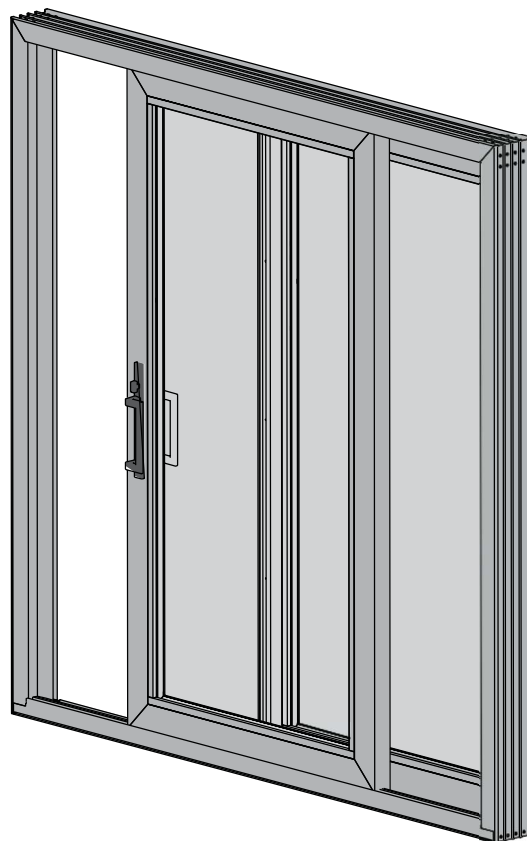

ALPEN
HIGH PERFORMANCE PRODUCTS

Contents

1) Receiving and Inspection	4
2) Frame Assembly	5
3) Prepare Rough Opening (RO).....	133
<i>SILL PAN & FLASHING NOTES</i>	144
<i>SHIMMING GUIDELINES</i>	188
<i>SCREW FASTENER GUIDELINES</i>	188
4) Installing the Door	19
5) Install Fixed Panel.....	22
6) Panel Installation: 4 Panel (OXXO) DOOR.....	25
7) Install Dust Plugs	27
8) Install the Fixed Panel Interlock.....	28
9) Install the Active panel.....	29
10) Fasten Top Dust Plug.....	30
11) Adjust Panel Rollers	30
12) Install Head Stop Bumper.....	31
13) Install the Handles and Check/Adjust Locks	32
14) Secure Keeper: Grandline 3-Panel (OOX/XOO) and 4-Panel (OXXO):.....	33
15) Installing the Insect Screen.....	33
16) Final Check for Square and Door Operation	34
17) Complete Flashing	35
18) Finishing Up.....	36

FRAME KIT COMPONENTS

2-Panel Door

Qty	Part #	Components	OXO	OOX	OXXO
1	SV5202/5201	Door Frame with Sloped Sill			
1		Sliding (Active) Panel			
1		Fixed Panel			
1	SV5205	Interlock for Fixed Panel			
1	SV???	Fixed Panel Riser			
1	SV5222	Fixed Panel Block			
1	GWC5234	Door Bumper Stop	1	1	2
1	GWC5232	Bottom Dust Plug – Sliding Panel			
1	GWC5231	Top Dust Plug – Sliding Panel			
2	GWC082218	Fixed Panel Anchors / L-Brackets	4	4	4
2	FGL1235.003	Weep Hole Covers	4	6	8
2		Hole Plugs – Operable Panel Rollers	2	2	4
4	#8 x 3/4" PH	Fixed Panel Interlock Screws	4	4	8
2	#8 x 1-1/2" PH	Fixed Panel Riser Screws			
3	#10 x 1" CSK	Fixed Panel Anchor Head/Sill Screws			
2	#8 x 3/4" CSK	Fixed Panel Anchor Panel Screws			
2	#8 x 5/8" Self Tap	Door Bumper Stop Screws			
4	??	Top / Header Dust Plug Screws			
2	??	Bottom Dust Plug Screws			
2	??	Fixed Panel Block Screws			
20	#10 x 3"	Installation Screws			
20	1/2" Hole Plugs	Installation Plugs (Black or White)			
1	40.94 / 40.70	Handle Set with Screws & Gaskets			

3-PANEL AND 4-PANEL KIT COMPONENTS:					
0	SV5206	Astragal	0	1	1
0	1/2" Hole Plugs	Astragal Hole Plugs (Black or White)	0	4	4

FIELD-ASSEMBLED FRAME KNOCK-DOWN (KD) KIT COMPONENTS:					
1	SV5202	Head frame			
2	SV5202	Side Jamb frames			
1	SV5201	Sloped Sill			
2	GWC5230	Frame Corner Key – Head/Jamb			
32	#10 x 1-1/2" PH	Head/Jamb Screws			
8	#10 x 1" PH	Sill/Jamb Screws			
2		Xtrabond 9500 Polyurethane Sealant (White, Dark Bronze, Almond, Silver)			

Sliding Glass Door Installation

Understanding the design and conditions of the building envelope under consideration is important for proper installation of fenestration products. Building materials, methods, and designs vary between projects. It is the responsibility of the installer to determine the proper installation method. Please consult your architect or a construction professional if necessary. No less than two (2) people are required for installation.

QUICK-GLANCE PLANNING:

- Rough Opening framing must be **at least**:
 - **3/4" wider** than the door frame width and
 - **1/2" taller** than the door frame height.

Dimension	Formula
Rough Opening Width	Door Frame Width + 3/4"
Rough Opening Height	Door Frame Height + 1/2"

This provides sufficient space to accommodate any flashing buildup without encroaching on the shim space, allowing the door to "float" and remain unaffected by building movement.

- Installation screws for wood frame structure are included in your installation package. If your structure is not wood, consult "Appropriate Alternative Screws" Tables in Section 8

1) RECEIVING AND INSPECTION

- A. Inspect each door thoroughly upon delivery. Ensure each door is the proper type, operability, and dimensions. Check for any shipping damage and report it immediately to Alpen.
- B. If installation will not take place immediately after the door is delivered, proper storage techniques must be followed. Below are the recommended storage methods and guidelines.
 - Transport doors in an upright position with manufacturer's packaging in place. Store doors in an upright position (as close to 90⁰ as possible), on the sill, on a flat & level surface, and away from any moisture. If door panels are not inside the frame, they must be stored in a vertical position at 90⁰ to the ground.
 - Do not lay, transport, or carry the door while in a flat (table-top) position.
 - Handle units with shipping handles or glass suction cups as much as possible.
 - Do not stack doors against each other. Do not stack any other materials or products against the door.

REMEMBER TO USE APPROPRIATE PERSONAL PROTECTIVE EQUIPMENT AND PROVIDE ADEQUATE MANPOWER AND EQUIPMENT FOR LIFTING HEAVY DOORS

REMEMBER:

Always check door operation before applying final sealants and trim!! Incorrect operation is a sign that something is wrong with the installation and door may need to be re-set.

2) FRAME ASSEMBLY

TOOLS REQUIRED: DRILL • 1/8" DRILL BIT • CAULK GUN • CLAMP • STRAIGHTEDGE • MINERAL SPIRITS

A. CONNECT HEAD AND JAMBS

- 1) Clear a spacious, level work area for assembling the door frame.
- 2) Lay out these door frame components with the **exterior** side facing up.

(1) Head Frame	(32) #10 x 1/2" Pan Head Screws
(2) Jamb Frames	(1) Tube of colored Xtrabond 9500 Sealant
(2) Head/Jamb Corner Keys	(1) Sill (to be installed in a later step)

- 3) Test fit Corner Key into Head Frame and align it with a Jamb Frame to determine correct orientation.
(Fig. 1)

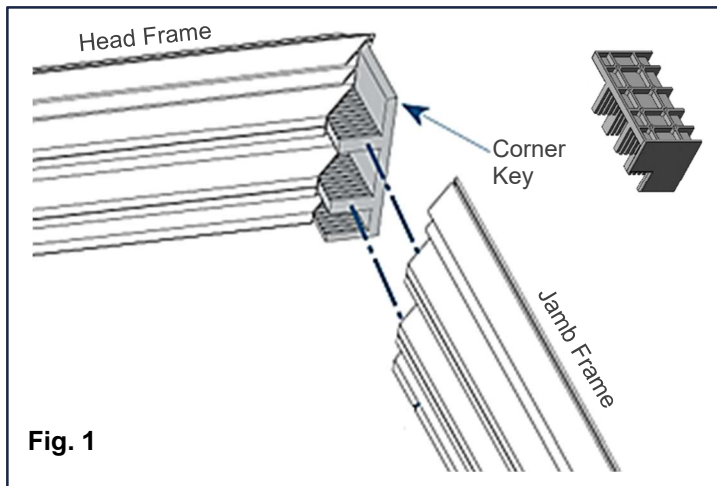
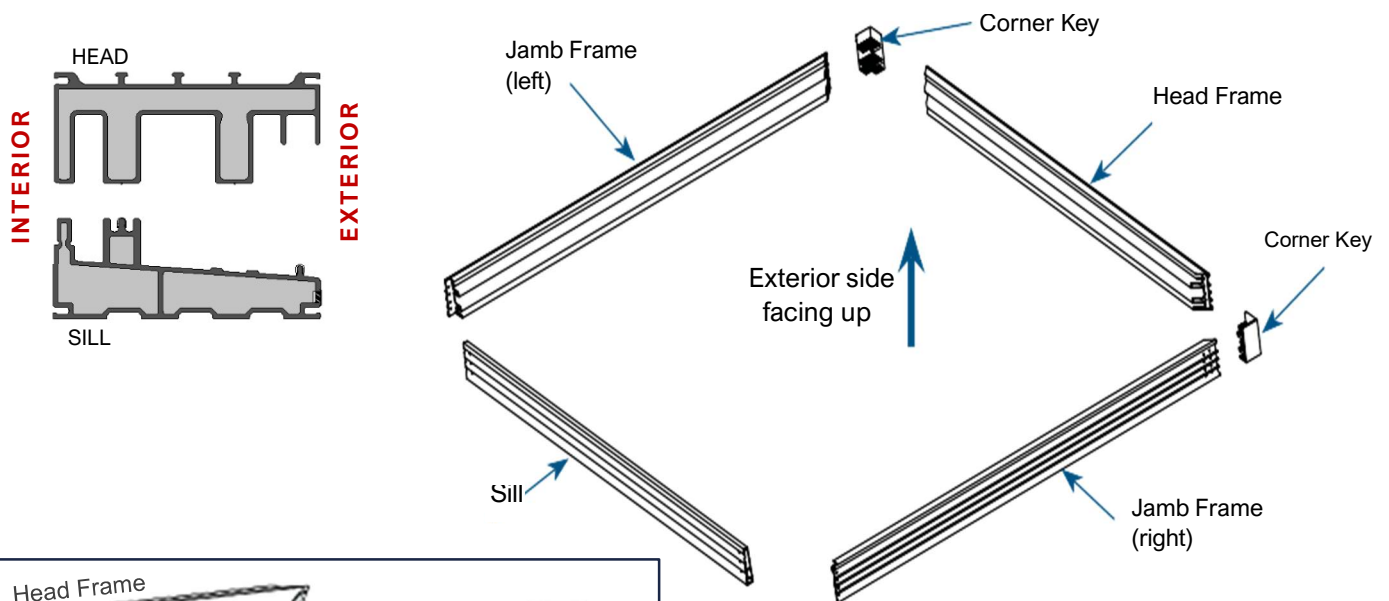

4) Apply Sealant (**Fig. 2**)

- In Corner Key: Fill all screw holes with Xtrabond® 9500 Sealant.
- On Frames: Apply the sealant to the angled ends of the Head and Jamb Frames

5) Connect Jamb Frame to Head Frame (**Fig. 3**)

- Insert the Corner Key into the Head Frame.
- Insert the right Jamb Frame into the Corner Key.
- Push the framed pieces tightly together to ensure the corner is a tight fit. Ensure there are no gaps along the miter between the Jamb and the Head Frames. (**Fig. 3**)

Fig. 2

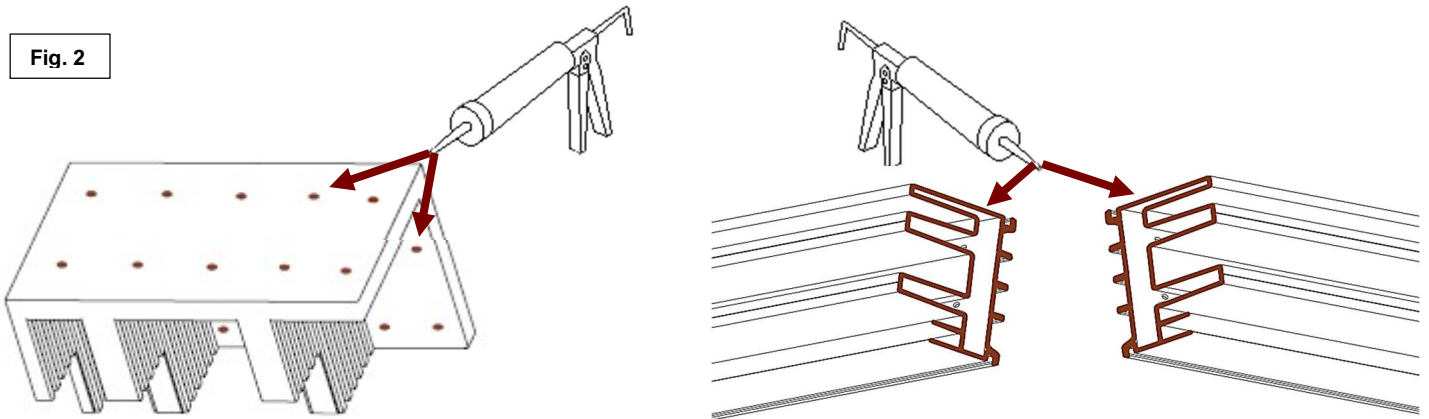
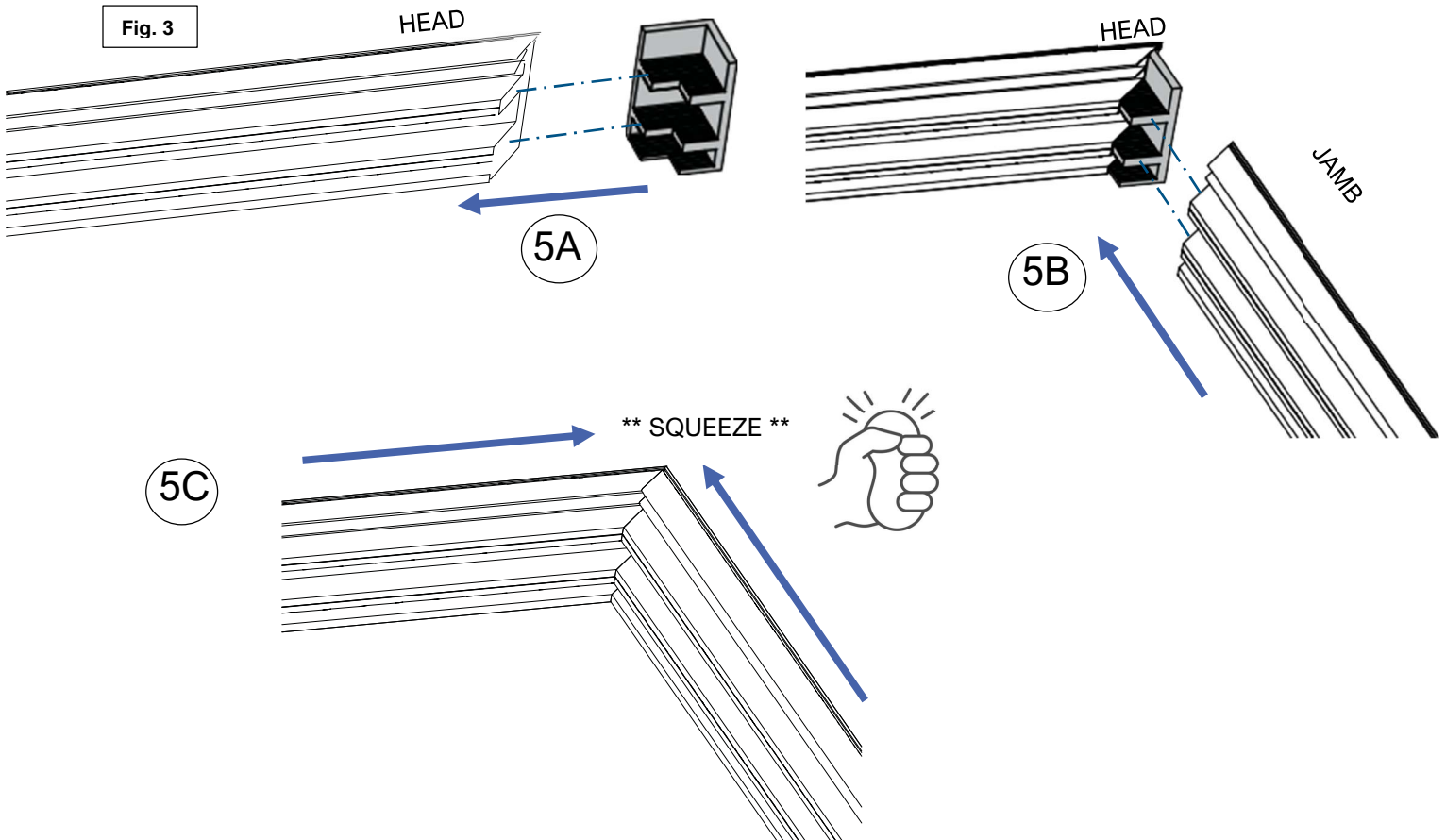
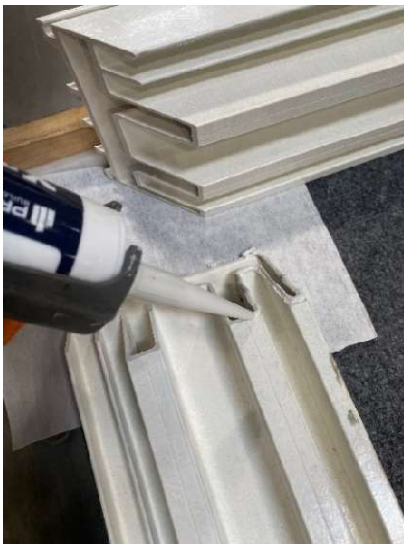
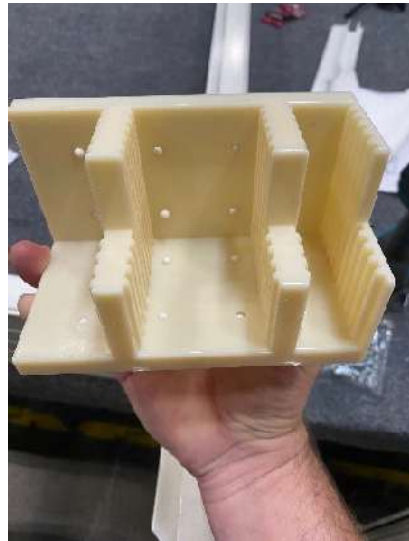

Fig. 3





6) FASTEN

Install the **(32) #10 x 1/2"** Corner Key Screws in the EXACT sequence shown in (Fig. 4 – 7)

Fig. 4

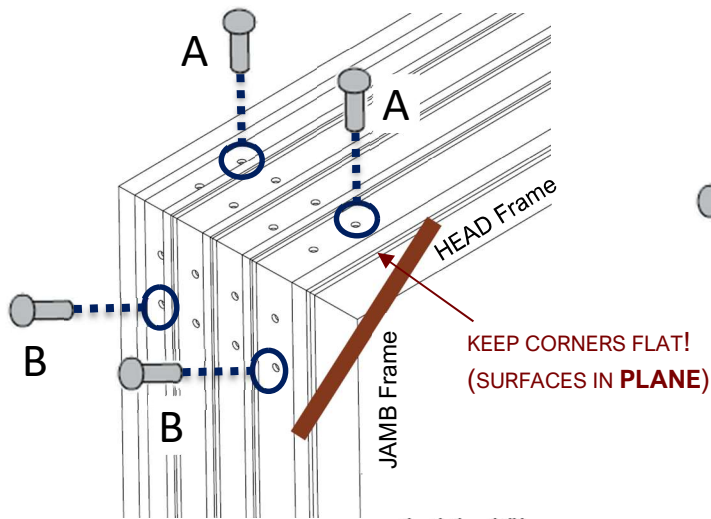

Fig. 5

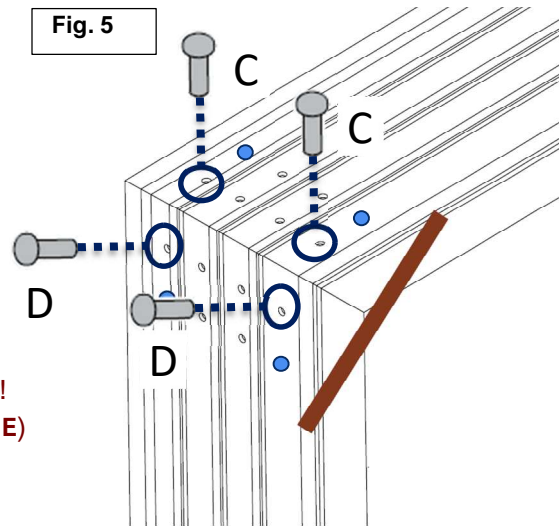

Fig. 6

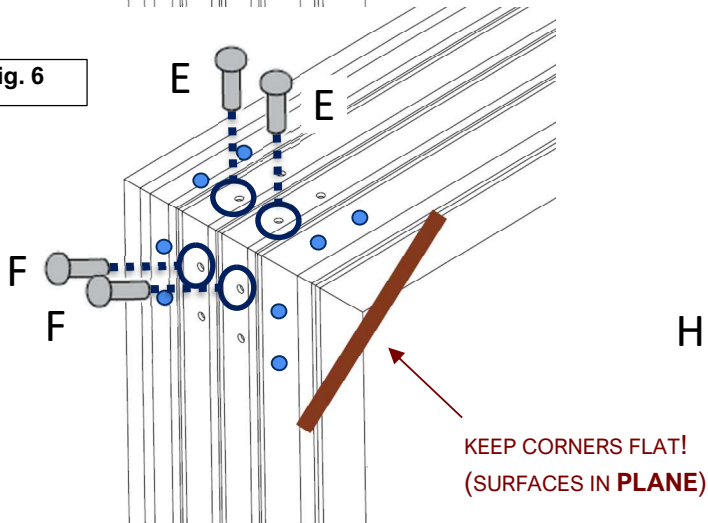
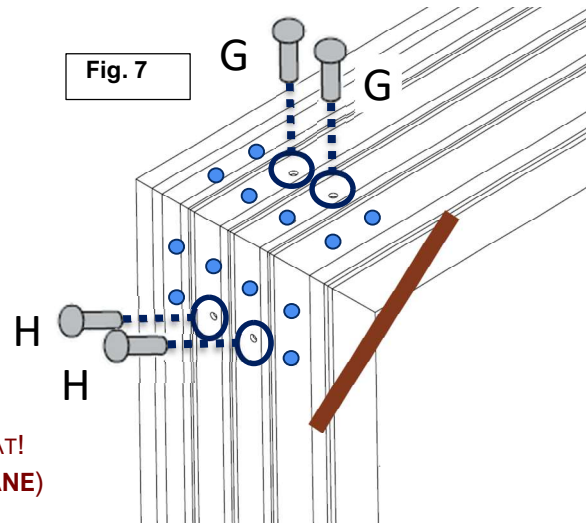

Fig. 7



ALL SCREWS MUST BE INSTALLED. THERE SHOULD BE NO SCREWS REMAINING.

7) CHECK, REPEAT AND CLEAN

- **Check** that the frame elements are in PLANE (flat, all frame faces are perfectly flush with each other, the miter joints are perfectly aligned with each other) and that the corner is drawn tightly together.
- **Repeat** step 9 to install screws to secure the head to the other side jamb.
- Fill the screw holes on the frame with sealant.
- **Clean** the sealant off the frames using mineral spirits.

B. ASSEMBLE THE SILL

- 1) Locate and Check Sill: Locate sloped sill and check ends to make sure sill gasket is in place. **(Fig. 8)**
- 2) Position the Sill: Place the sill near frame with the exterior side (weep holes) facing up. **(Fig. 9)**
- 3) Clean Surfaces: Use isopropyl alcohol to remove debris from ends of the sill and jambs.
- 4) Align Frames: Locate the screw holes at the bottoms of the jambs. Do not remove the sill gasket!
- 5) Apply **copius** amount of sealant to bottom of frame jamb interface at sill ****Interior and Exterior****
- 6) Tightly Press Frames Together: Tightly press the Jamb Frame up to the Sill to compress the Sill Gasket and sealant. **(Fig. 10)**
 - Surfaces must be **flush** and **in plane** with each other (flat)
 - There must be no gaps along the miter between the Jamb Frame and the Sill.

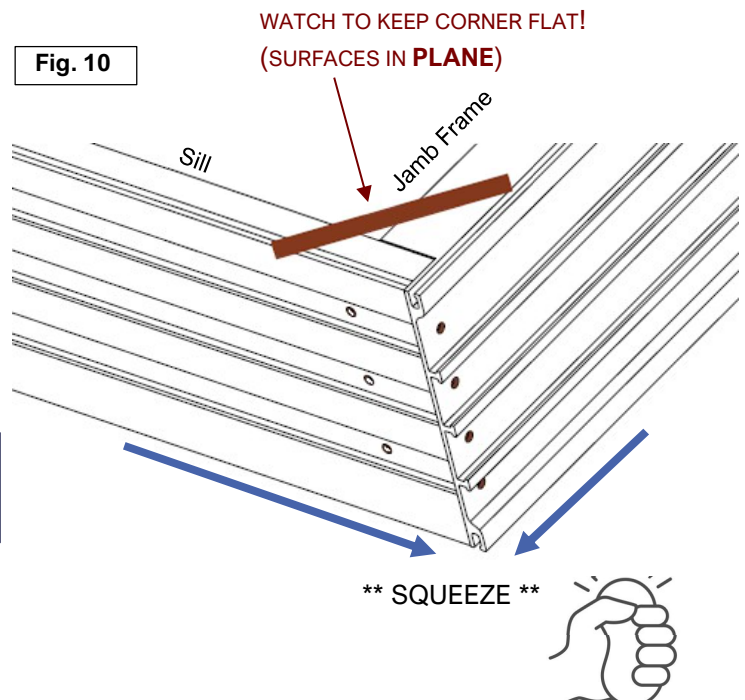
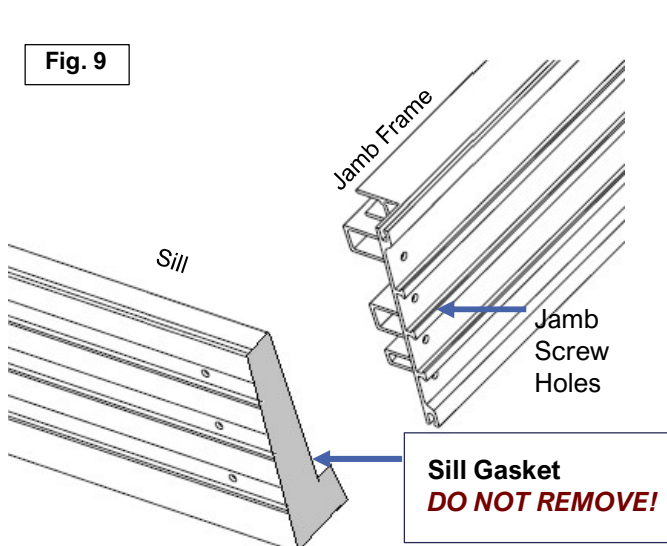
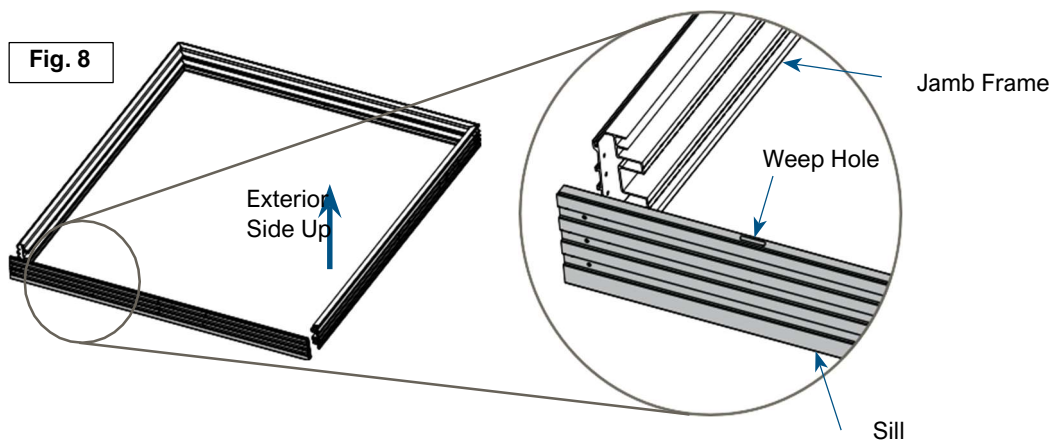

- 7) Squeeze Sealant into Jamb Frame Screw Holes: Apply Xtrabond 9500 (provided). (Fig. 11)
- 8) Attach Screws into Outer Holes: Start on one side and insert a #10 x 1" screw into the bottom hole (nearest you), then into the top hole (farthest from you), pulling the profiles together. (Fig. 12)
- 9) Repeat on the Other Jamb: Installing screws in only the outer holes. (Fig. 13)
- 10) Insert the middle screws on both sides.
- 11) Check Alignment: Verify that the sill and jamb profiles are aligned in a flush manner, and the miter joint is tight.

Fig.11

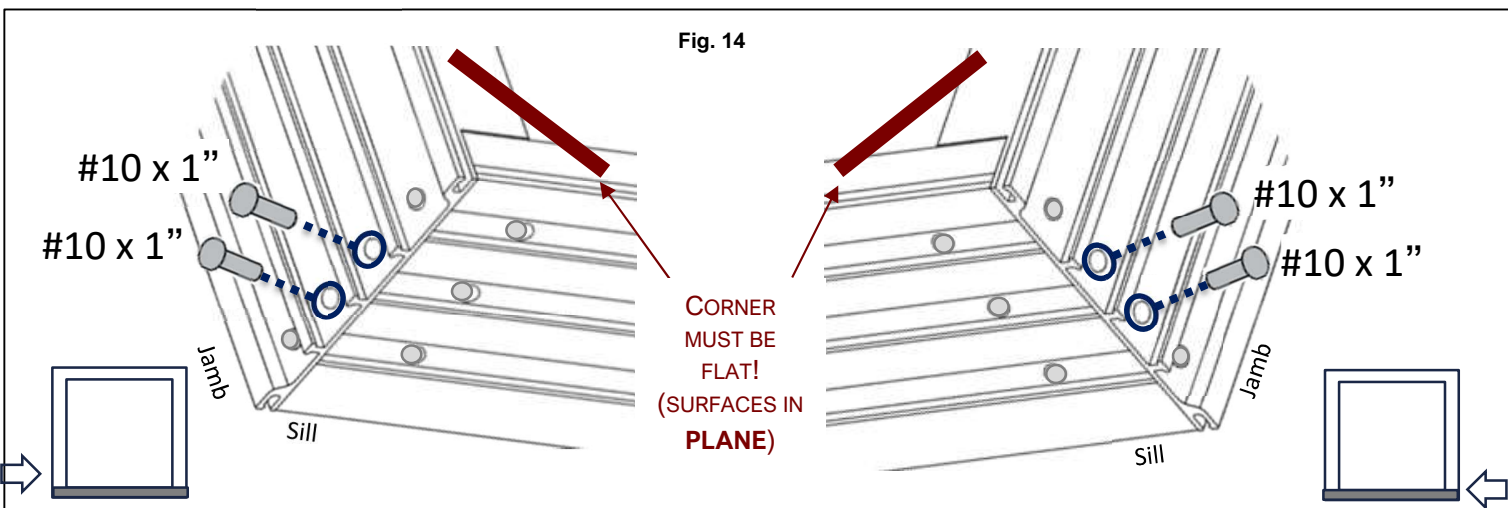
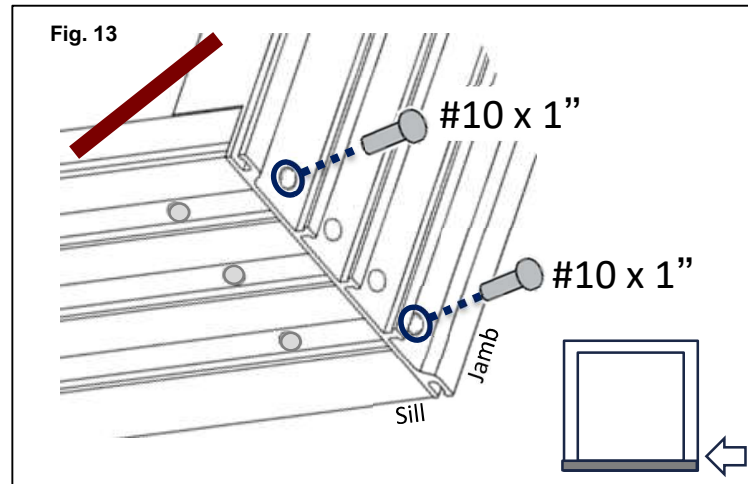
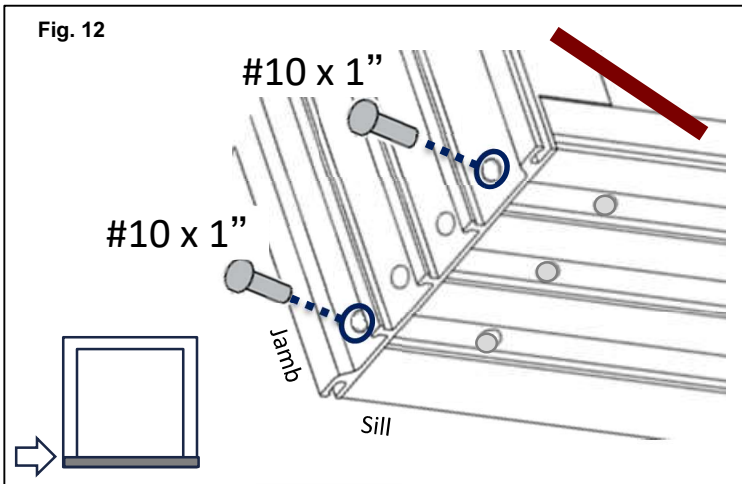
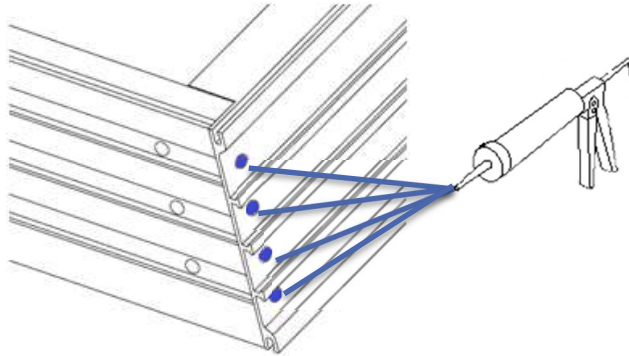

C. INSTALL THE FIXED PANEL RISER (IF NOT ALREADY INSTALLED)

- 1) Orient the Fixed Panel Riser: So that the notched end is toward the Jamb on the Fixed Panel side. **(Fig. 15)**
- 2) Insert L-Bracket Screw Reinforcement Block: Slide the L-bracket Screw Reinforcement Block into the straight-cut end of the Fixed Panel Riser so that it is flush to the end. **(Fig. 16)**
- 3) Set the Fixed Panel Riser onto the Sloped sill and slight tight against the jamb frame. **(Fig. 17)**
- 4) Align pre-drilled holes: In Fixed Panel Riser with pre-drilled holes in the Sloped Sill. **(Fig. 18)** There are 3 holes:
 - (1) hole close to the Jamb Frame (A),
 - (1) hole in the center (B)
 - (1) hole at the end through the L-Bracket Screw Reinforcement Block (C)

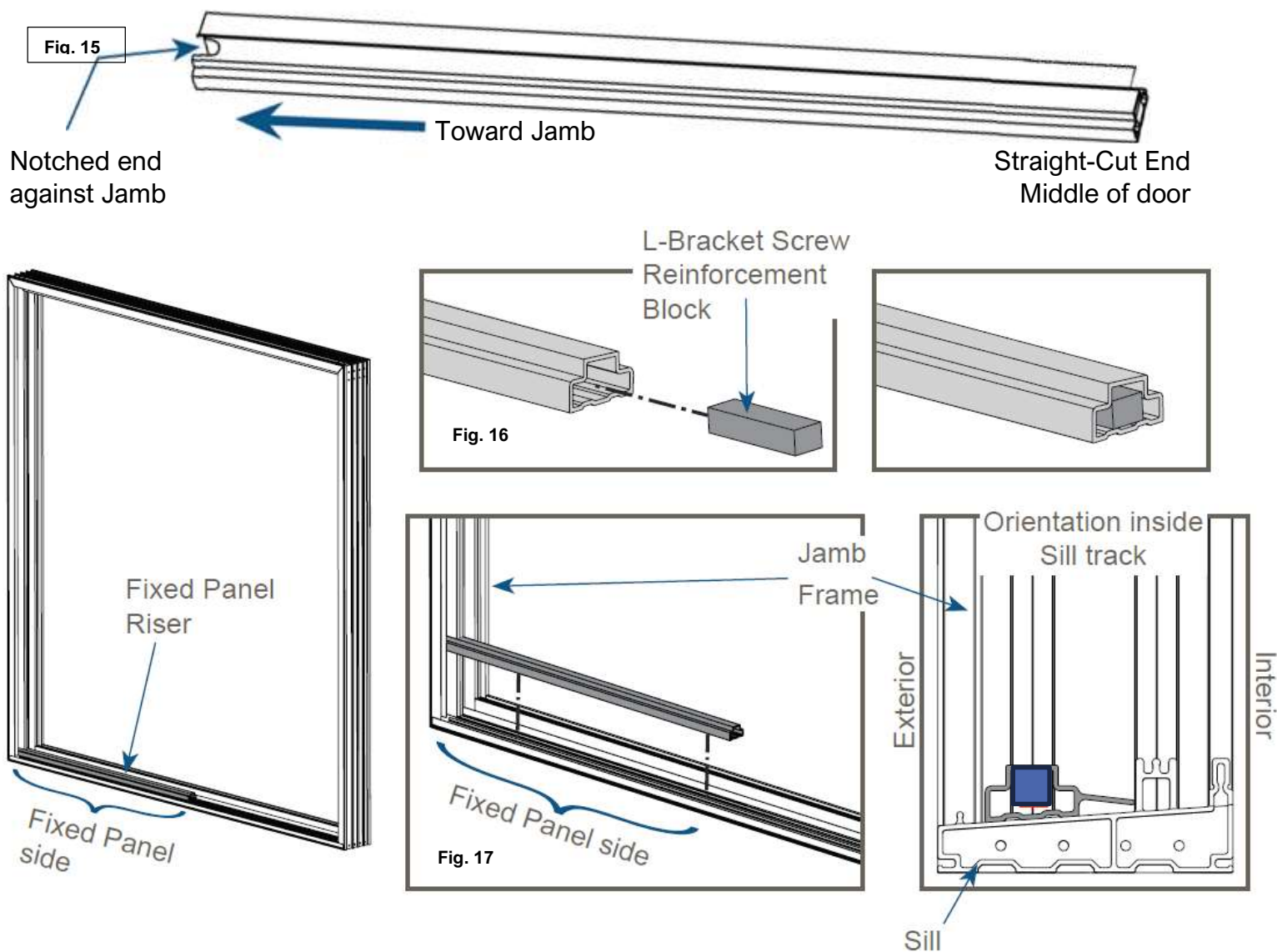

ORIENTATION REMINDER:

**Frame is still in a horizontal position on the work surface and the exterior side is facing UP.
(Images above shown with frame standing upright for reference purpose only.)**

- 5) Fasten through Hole “B”: Pre-drill \varnothing 1/8” hole and insert **one (1) #10 x 1-1/2”** Pan Head Screw into center hole on the Fixed Panel Riser
- 6) Fasten through Hole “A”: Pre-drill \varnothing 1/8” hole and insert **one (1) #10 x 1-1/2”** Pan Head Screw into hole closest to the Jamb Frame

Do not fasten (“C”) through the straight-cut end of the Fixed Panel Riser and Fixed Panel Block yet. (“C”) is fastened when the fixed panel anchors are installed.

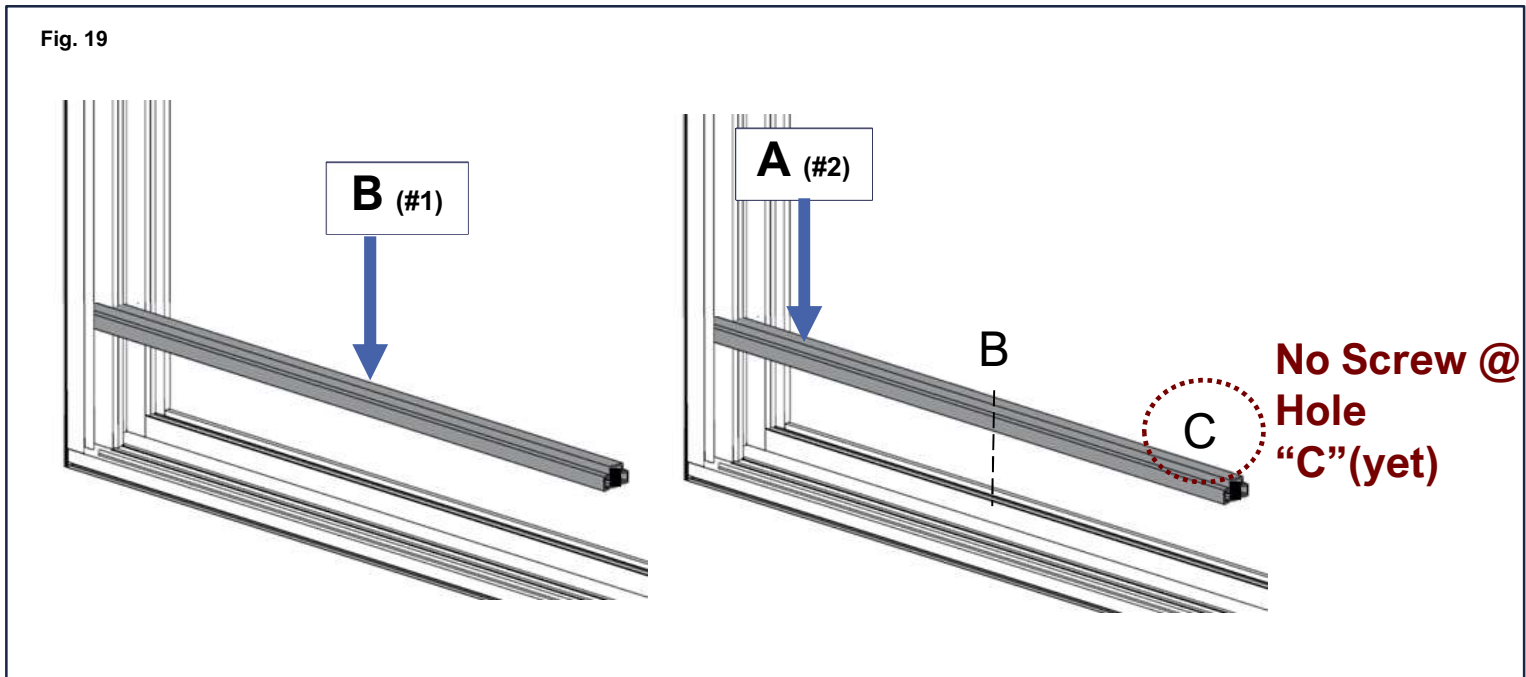
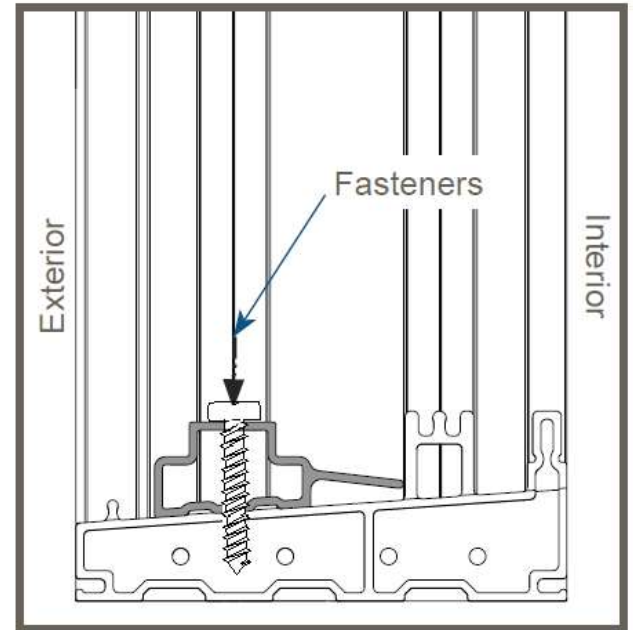
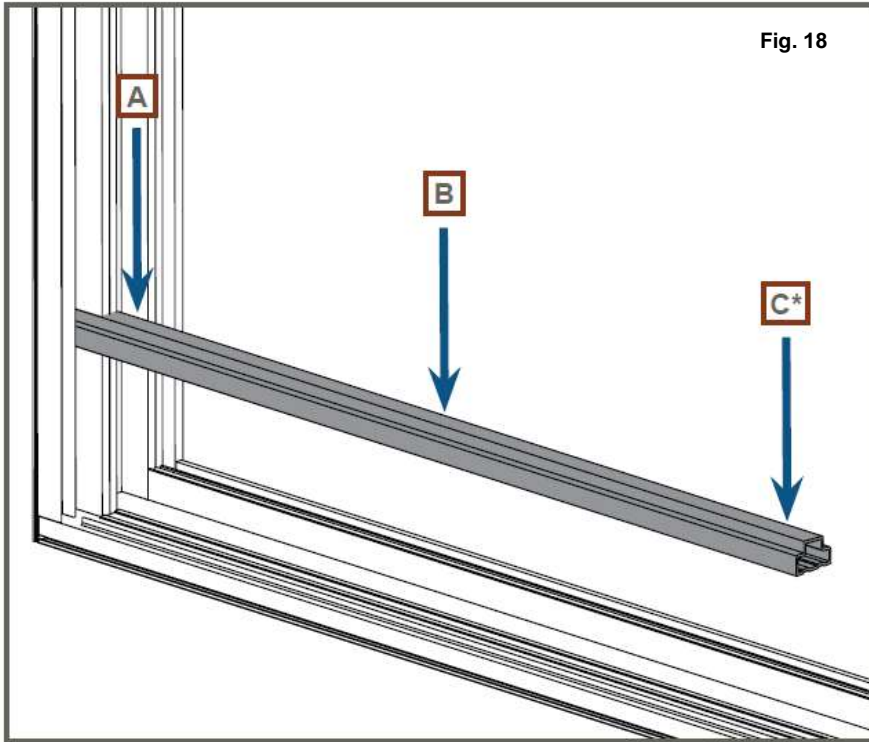

3) PREPARE ROUGH OPENING (RO)

TOOLS REQUIRED: 6 FOOT LEVEL • FRAMING SQUARE

A. CHECK OPENING AND DIMENSIONS

- 1) Ensure the opening is clean and free of debris.
- 2) Check SQUARE, LEVEL, PLUMB & FLAT (Fig. 20)
 - **SQUARE:** Measure the distance between opposite corners. If the measurements are the same, the opening is square. Use a **framing square** to check each corner of the RO.
 - **LEVEL:** Use a **6-foot level** to determine if the sill and header are level, and the jambs are plumb.
 - **PLUMB:** Use a **6-foot level** to check that all members of the wall are straight and parallel.
 - **FLAT:** Lastly, check that the sub-floor is flat, straight, and level.

3) MEASURE Rough Opening. (Fig. 21)

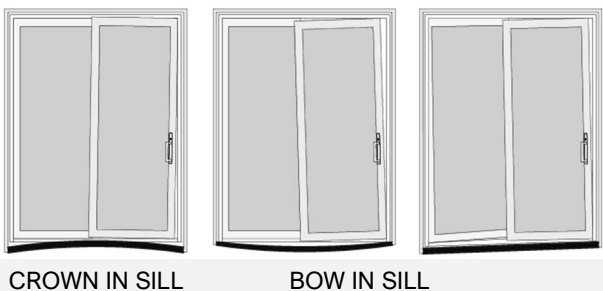
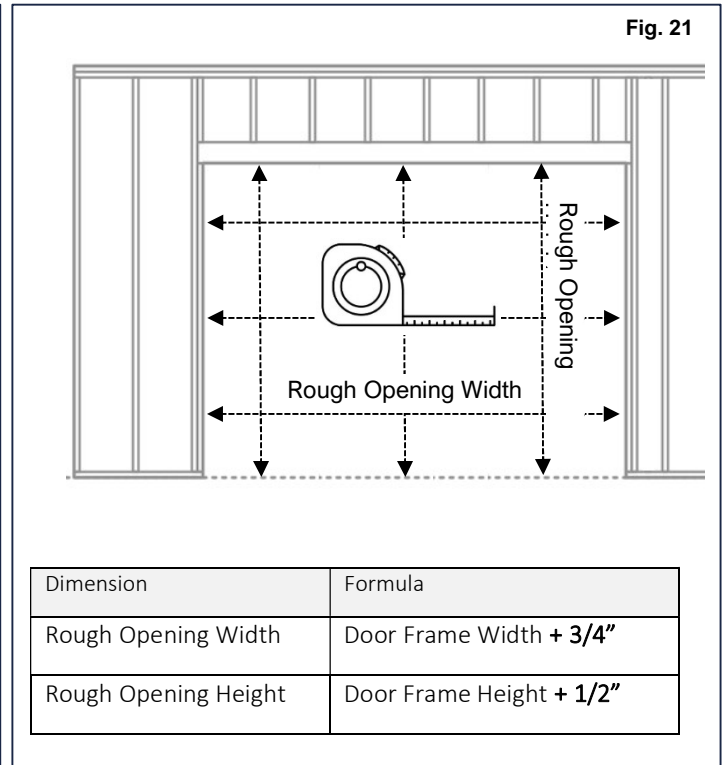
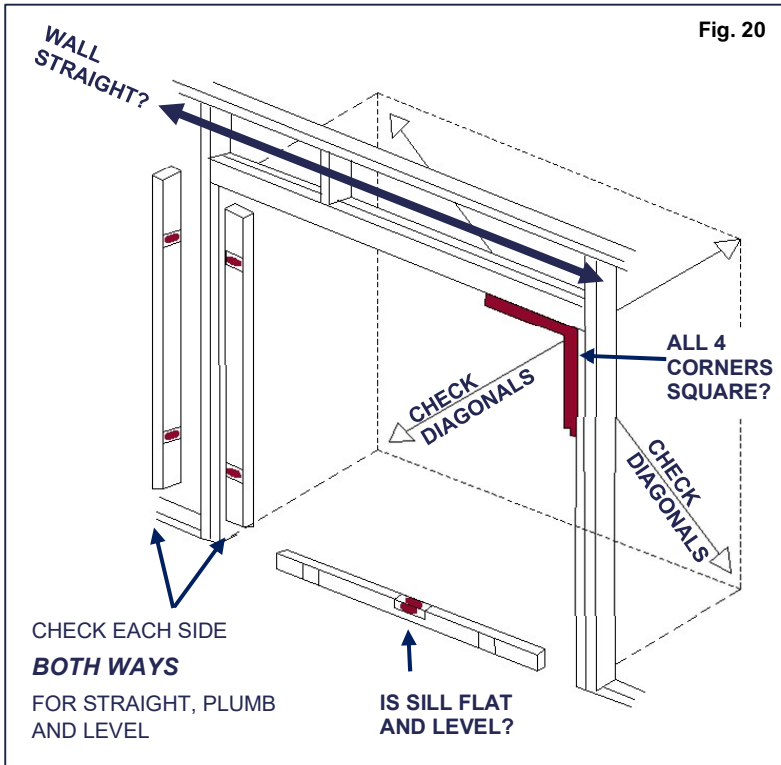

Pro Move: Start with a Flat and Level Sill

The number one cause of poor door performance is an un-level sill. Sills with any **crown, bow, or slope** prevent the interlocks and weather stripping from engaging, leading to frustrating issues. If you start with a level sill, good results are all but assured. If the sill is not level, bad results will surely follow.

For best results, ensure the sill is perfectly flat and level before installation

SILL PAN & FLASHING NOTES

This installation packet includes the recommended guidelines for applying flashing, which align with typical best practices. In all instances, follow the instructions provided by the architectural documents, building engineer and Weather Resistant Barrier system manufacturer. For complete guidelines and training on proper flashing application, refer to ASTM E2112-01 and AAMA Installation Masters.

Following these practices will help establish a secure seal between the door and rough opening (RO) while effectively channeling water to the exterior of the structure.

Alpen strongly recommends using sill pan flashing for door installations whenever feasible. The Sill pan flashing enhances water resistance and reinforces the building's enclosure integrity.

The sill pan flashing can be pre-formed or built in-place but must always be modifiable to custom-fit the specific sill condition, extending fully beneath the door to match the sill's shape. Always provide interior upstanding leg (back-dam) that is minimum 1-3/4" tall and use end caps that are at least as tall as the interior upstanding leg of the sill pan. Seal all joints between the sill pan and end caps (see Fig. 22). For more details on back dam heights, side jamb heights for flashing, redundant sealant lines, and flashing in a weatherboard fashion, please refer to the Installation Masters guidelines.

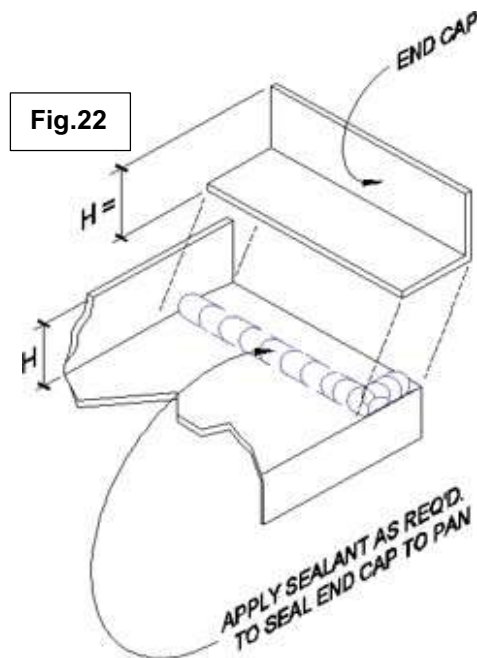

Source: AAMA Installation Masters Training Material

It is essential to insulate the cavity between the rough opening (RO) and the door frame, as well as seal the door to the interior of the building before the interior trim-out. This should be done in the manner best suited to the specific opening conditions.

B. APPLY SILL FLASHING AND SILL PAN

- 1) Clean the opening: Ensure it is dry and free from dirt, oil and debris.
- 2) Install Sill pan flashing: Install 9" wide, flexible flashing on the sill, overlapping the sill plate, and up the jambs, 6" to 9" high. (See Table 2 on Pg.15 for flashing length formulas.)
- 3) Prepare a Sill Pan with Back-Dam:
 - Prepare pre-manufactured plastic pan or flexible flashing sill pan. Sill pan should have a 1-3/4" tall back-dam and end-dams and extend 2" across the face of the sheathing.
 - Place the sill pan on top of the sill pan flashing to make sure it fits tight between the jambs with the lip of the sill pan against the sill plate. Check that it is level.
 - If the condition is not level, use leveling shims under the sill pan as opposed to under the door (**Fig 1**). Use flat shims of 1/8" or less set in bed(s) of sealant.
- 4) Install sill pan:
 - Apply two 3/8" beads of sealant on top of the flashing, extending full width of sill. Place one bead on the interior side and one on the exterior side where the sill pan will make contact. Continue both beads up the jambs to seal the end-dams.
 - Carefully place the sill pan into position, pressing it down onto the sealant beads and over any applied flexible flashing materials.
 - Check that sill pan is level again.

Fig. 1

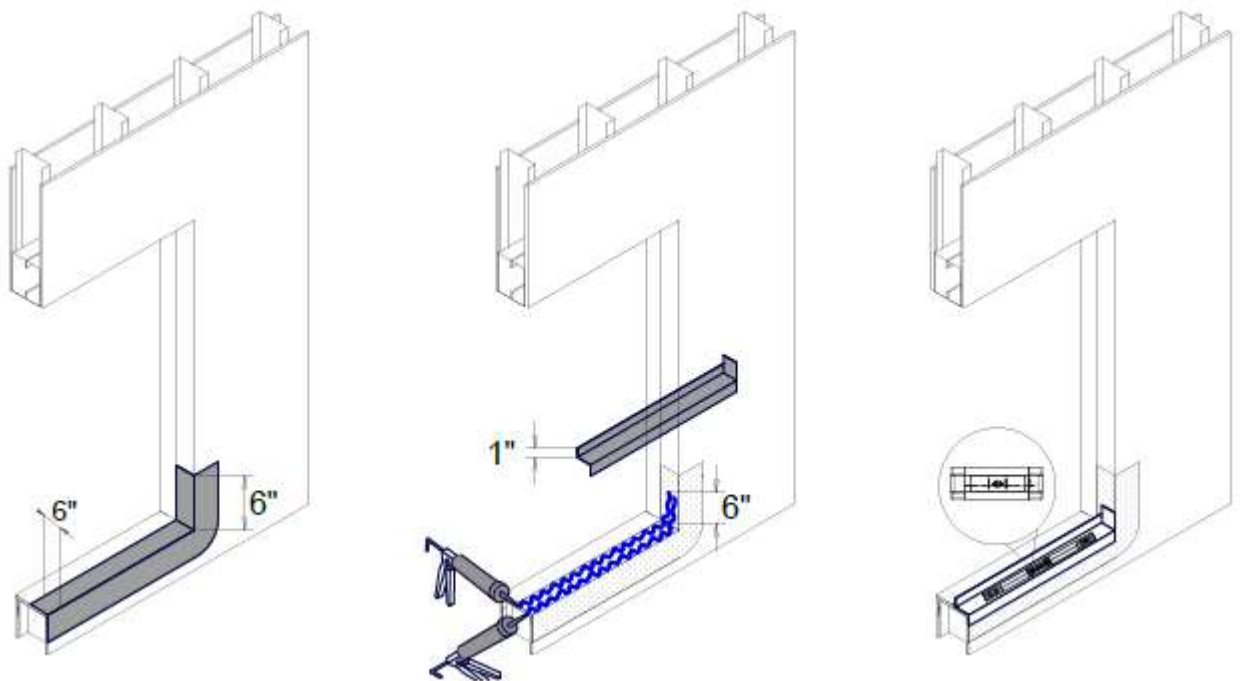

C. APPLY HEAD AND JAMB FLASHING

- 1) Starting at the top, work flexible flashing down each jamb. If using tapes, apply tapes starting at the inside and work toward the outside, pressing out any bubbles or voids.
- 2) Seal bottom of Jamb Flashing: Jamb Flashing overlaps the sill pan at the bottom, apply sealant as needed to ensure water-tight corner.

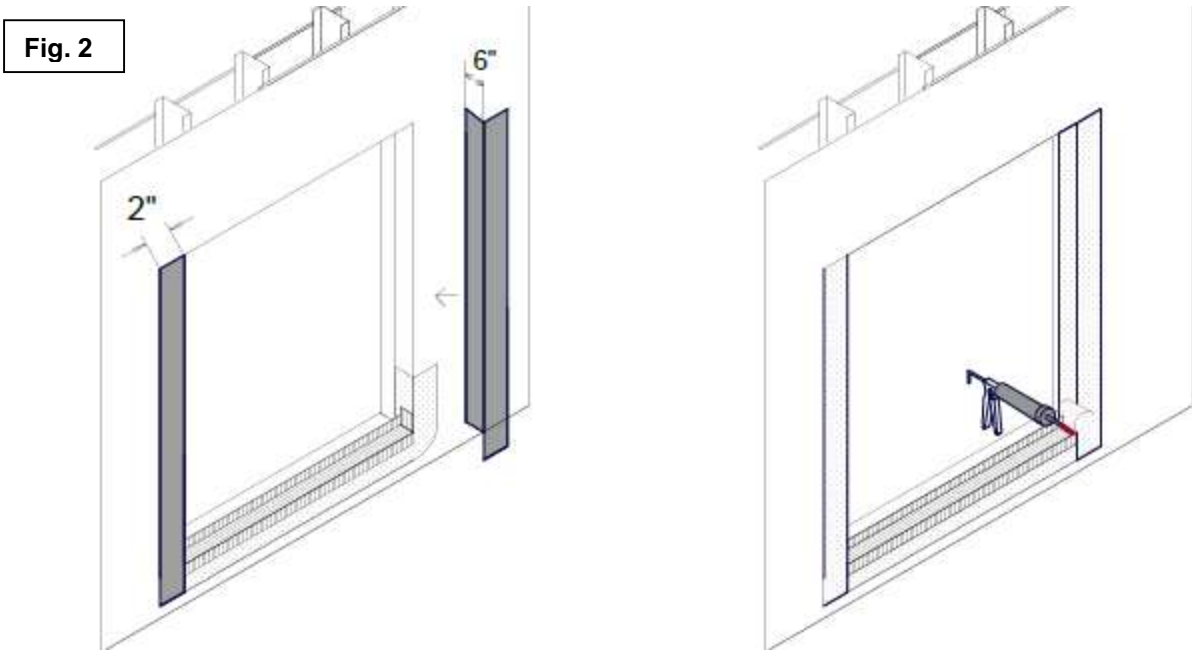

PRO TIP: Choose flexible flashing that is properly sized (See Table 2) to provide the following:

- Length should be long enough to cover the full height of the jambs and overlap the Sill Pan at the bottom.
- Flashing should extend minimum 6” into the opening so that end of flashing is at least ½” behind the inside edge of the door frame to ensure that the interior air seal is applied to both door frame and flashing.
- Flashing should extend minimum 2” across face of sheathing.

Table 2	
Flashing Lengths and Cut Formulas	
Sill Flashing	= RO ^W + (2 x Flashing Width)
Jamb Flashing	= RO ^H + (2 x Flashing Width) – 1”
Head Flashing	= RO ^W + (2 x Flashing Width) + 2”
Legend	
RO = Rough Opening	
RO ^H = Rough Opening Vertical Height	
RO ^W = Rough Opening Horizontal Width	
Source: AAMA Installation Masters Training Material	

D. APPLY HEAD FLASHING

1) Flash across the Head of the opening

- Wrap Flashing: Like at Jambs, head flashing should overlap sheathing minimum 2" and wrap into opening minimum 6".

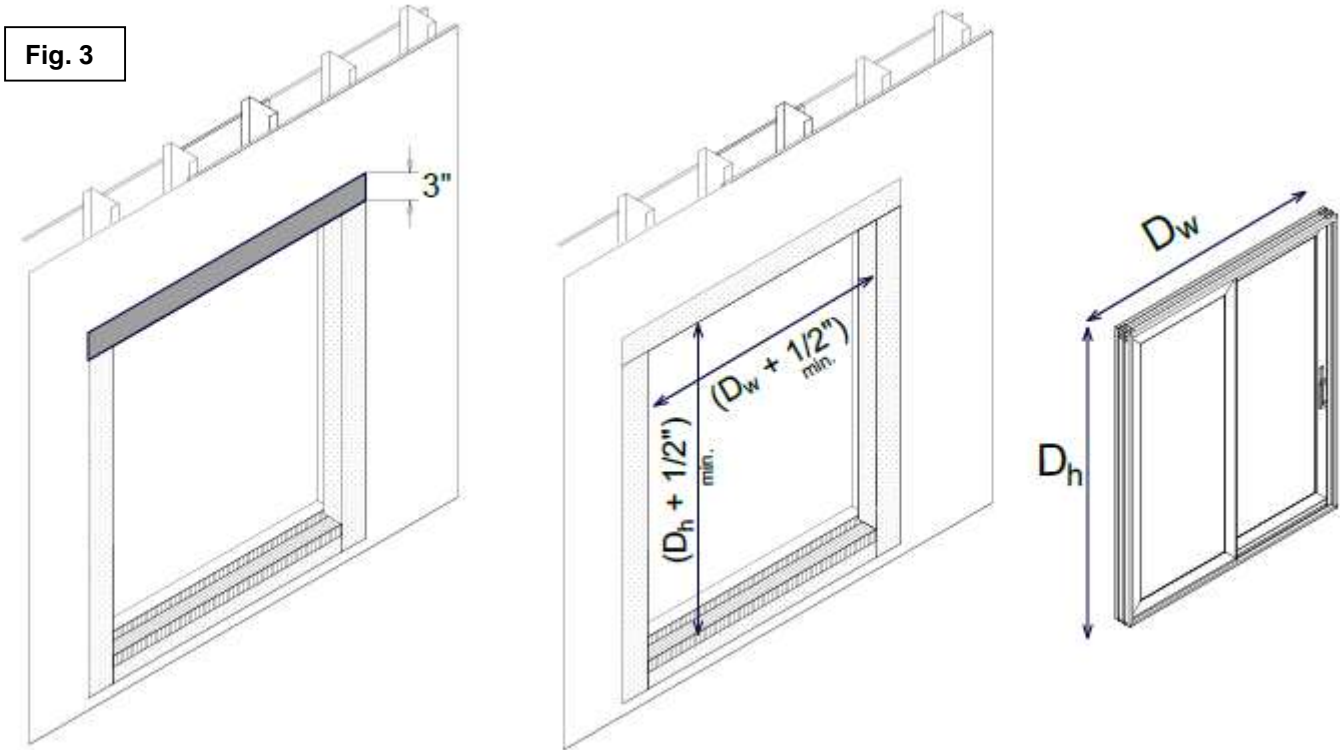

E. MEASURE THE RESULTING FLASHED OPENING:

2) The new door must be 1/2" to 3/4" smaller in width and 3/8" to 1/2" smaller in height than this measurement.

- It is recommended to dry-fit the door into place at this time to check fit, plumb and level. If shims are necessary, use maximum 1/8" thick plastic horseshoe shims, set in bed of sealant.
- Center the door in the opening and determine the shim size needed to keep it straight while anchoring. Use 1/4" horseshoe shims or a *WinBag™* inflatable shim for tighter spaces.



The *WinBag™* is an inflatable temporary air shim designed to help level and position doors and windows. Made from durable, flexible material with a manual pump, it allows precise adjustments by inflating to the desired thickness.

For door installation, it easily aligns frames for a secure, square fit, preventing long-term issues like sagging or misalignment.

Source: winbagusa.com

SHIMMING GUIDELINES

Installation and adjustment of shims must abide by the following guidelines.

There must be a shim at each fastening location.

- Shims shall be rectangular or horseshoe style, made of high impact plastic, 1/8” minimum thick.
- Never use wood shims
- Thicker shims may be required depending on the RO.
- If using tapered shims, always install them in complementary pairs with two shims oriented in opposite directions. This will ensure a flat level surface to support the door.
- Shims must be a minimum of 1 1/2” wide and long enough to provide continuous contact and uniform support across the entire depth of the door frame (5.5”).
- When securing the door frame, ensure that fasteners are inserted at shim locations and penetrate through the shim into the RO.
- Place lateral shims between side jambs and frame to square door.



SCREW FASTENER GUIDELINES

If Alpen-supplied screws are missing or not appropriate for your installation substrate, refer to **Table 3** for appropriate alternate screws.

SPECIFICATION	DESCRIPTION
MATERIAL:	High-quality, exterior-grade, corrosion-resistant stainless or coated steel; compatible with sealant materials (ASTM B766, B633, B456).
SIZE:	#10 x length as needed to embed at least 1-1/2” into RO structure.
TYPE:	As suited to RO substrate (Wood Screw Self-Tapping Sheet Metal Screw for Metal/Steel Structures Concrete/Masonry screw for CMU)
HEAD:	Flat, non-tapered head to fully cover 1/8” pilot hole.
POINT TYPE:	Self-drilling or self-tapping.

Screw Type	Application	Material
Self-Tapping Sheet Metal Screw	Thin metal frames or steel structures	Stainless or coated steel
Concrete/Masonry Screw (e.g., Tapcon)	Concrete or masonry substrates	Corrosion-resistant steel
Wood Screw	Wood framing or substrates	Stainless or coated steel
Structural Screw	High-load-bearing applications	Galvanized or stainless steel
Stainless Steel Deck Screw	Outdoor, corrosion-prone environments	Stainless steel

4) INSTALLING THE DOOR

ONLY BEGIN THIS STEP AFTER YOUR DOOR FRAME IS ASSEMBLED (IF KNOCK-DOWN KIT)

If your door is factory-assembled, you can start here. You may either set the door frame with the Fixed Panel already installed or remove the Fixed Panel first to reduce weight.

A. Apply Sealant

- 1) Across sill near the front (exterior) edge of sill pan: Apply a discontinuous 3/8" bead of sealant. Leave 2" gaps near corners and about 48" apart.
- 2) Across sill 1/2" away from Back-Dam: Apply a second 3/8" bead of sealant. Leave 2" gaps near corners and about 48" apart, slightly staggered from the gaps in the first sealant bead.
- 3) Across the face of the Back-Dam: Apply a continuous 3/8" bead of sealant across the back-dam (the up-turned leg of the sill pan) and 6" up each jamb.

Fig. 4

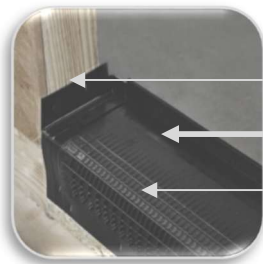
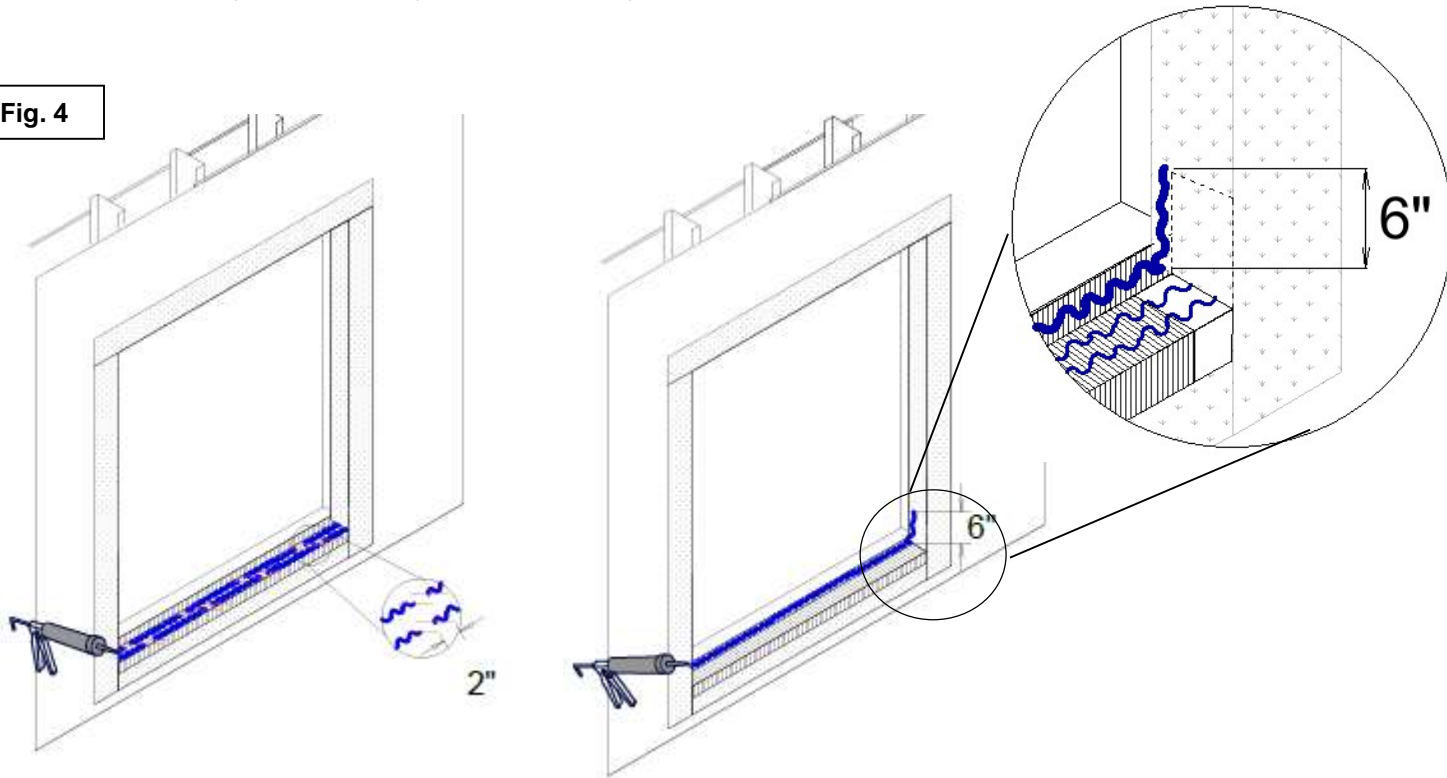

Sill Pan Terminology

End Dams: Side walls that prevent water from leaking beneath the sill pan from the sides.

Back-Dam: Stops wind- and pressure-driven moisture from damaging your floors.

Sloped Sill: Direct water outward and away from the opening.

Self-Sealing Material: These materials form a watertight seal around fasteners, resisting cracking or leaking when punctured, to offer superior moisture protection.

Source: VersaPan™ by Endura Products

B. Set and Secure the Door

- 1) Set the door frame near the rough opening (RO).
- 2) Locate the top two pre-drilled holes on the frame jambs (**Fig. 5**).
 - Remove hole plugs and **save them**.
 - These locations will be used as temporary anchor points.
- 3) Carefully lift the frame and set it onto the sill pan, keeping the pan sealant intact.
- 4) Insert shims the (top two jamb) temporary anchor points (**Fig. 6**)
 - Locate Shims behind (**Fig. 7**) or on either side of (**Fig. 8**) screw-hole location.
- 5) Use 1/8" Drill Bit to pre-drill through *Back Wall* of frame profile. (**Fig. 6**)
- 6) Install two (2) #10 x 3" screws (wood screws provided) in the pre-drilled holes to temporarily hold the door in place.

If Alpen-supplied screws are missing or not appropriate for your installation substrate, refer to **Table 3** for appropriate alternate screws.

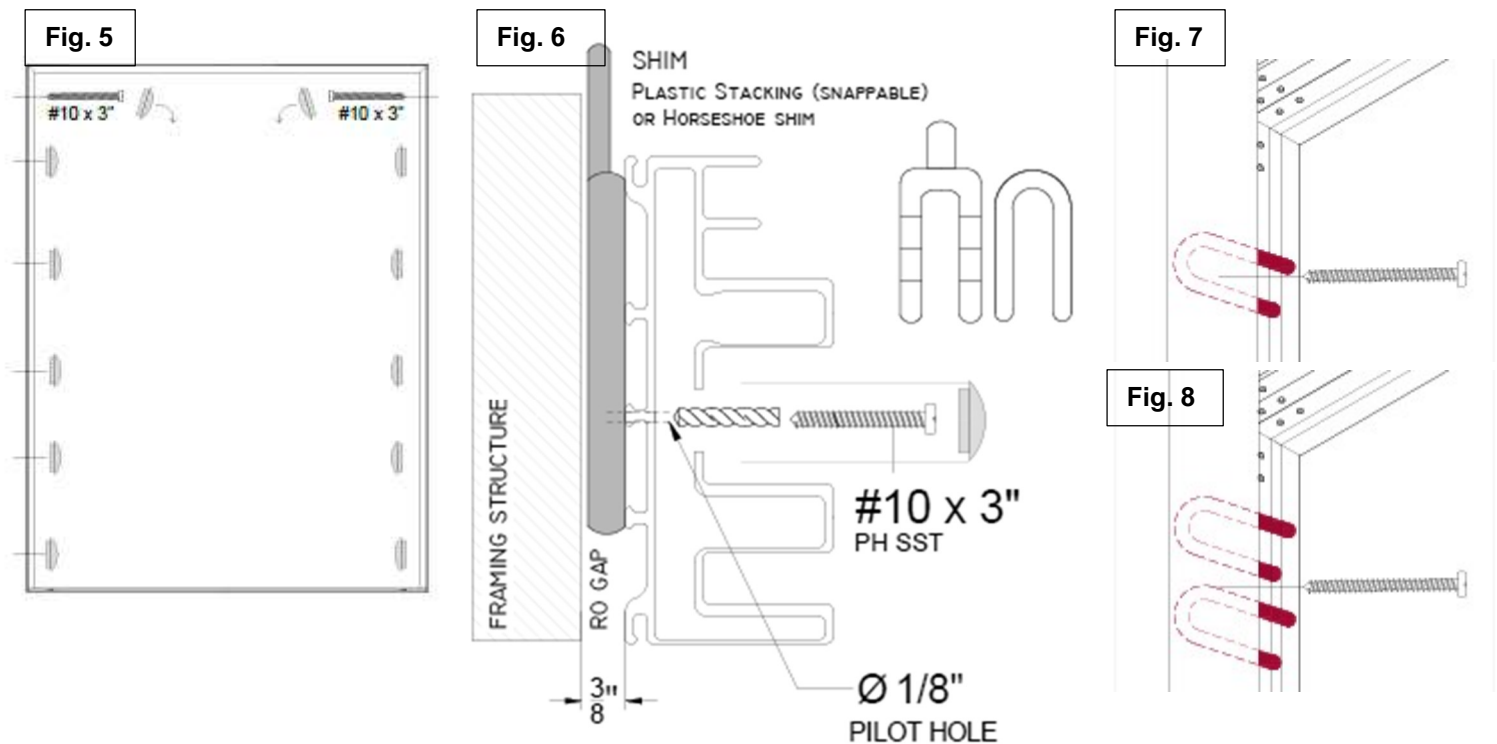

STOP! CHECK THAT THE DOOR FRAME IS SQUARE, LEVEL, PLUMB AND CENTERED IN THE OPENING

ADD SHIMS AS NEEDED

Shim as needed (see "Shimming" section). If adding shims at the sill, take care not to disturb the sill sealant.

C. Secure Jamb and Head: Locate the remaining hole plugs, remove them, and repeat steps 4–6

- Fasten the door through each pre-drilled pilot hole using the appropriate fastener, checking plumb, level, and square regularly, and adjusting shims as needed.
- ***Don't be afraid to set the panels to check for door operation early!*** (see next section) This allows for easier adjustments to the frame before final installation, avoiding the need to remove and reinstall the door later.

D. Ensure there are six (6) fasteners per jamb and five (5) across the head.

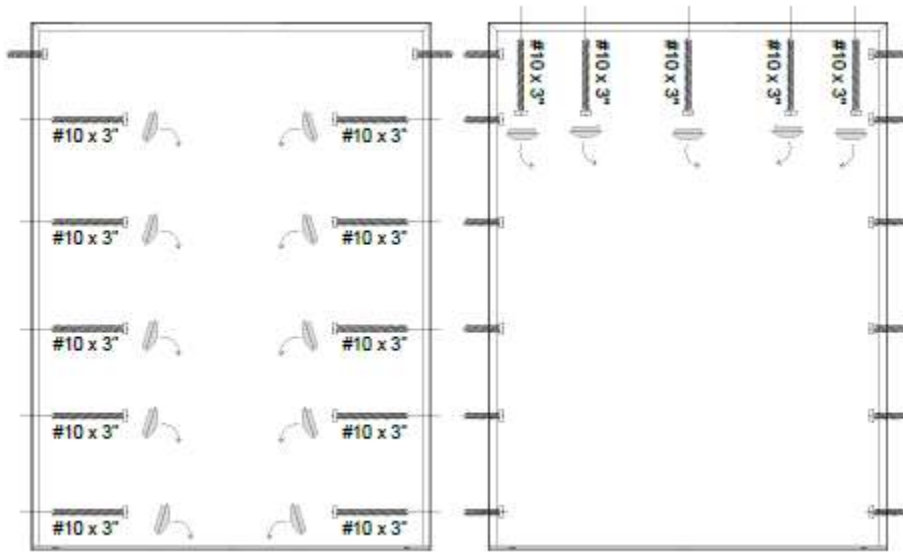

FOR RE-LOCATING SCREWS / DRILLING NEW SCREW-ANCHOR POINTS:

If there is a need to re-locate fastener holes (See Fig 10):

- 1) Use a \varnothing 1/2" **diamond** or **fishtail bit** and electric drill **with drill-stop**.
Not using the appropriate drill bit can result in tearing and fraying of the glass fibers in the door profile.
- 2) Drill a \varnothing 1/2" hole through the **FIRST WALL only**.
DO NOT DRILL DEEPER THAN 1/4"!
- 3) Pre-drill a \varnothing 1/8" hole through the **BACK WALL**
- 4) Add shims as above and fasten into the RO.
- 5) Extra hole plugs are provided in your installation kit

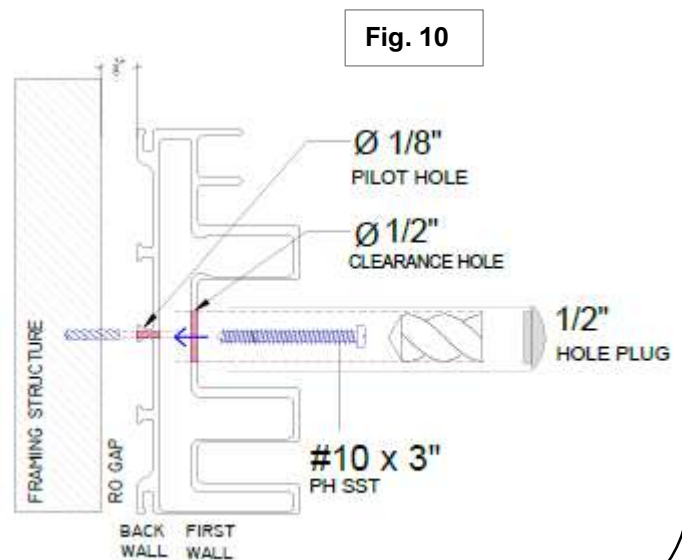

5)INSTALL FIXED PANEL

TOOLS NEEDED: GLASS CUP • 2 PEOPLE

A. INSTALL THE FIXED PANEL

- 1) Carefully lift the fixed panel up into the top portion of the installed door frame and gently set it down onto the **Fixed Panel Riser**.
 - Ensure the cut out in the top of the panel seats around the track in the frame (Fig.11)
- 2) Slide the fixed panel over into the side jamb until it is fully seated into the door frame jamb.
 - Ensure it is seated fully into the side jamb. Bottom should be flush with the end of the Fixed Panel Riser.

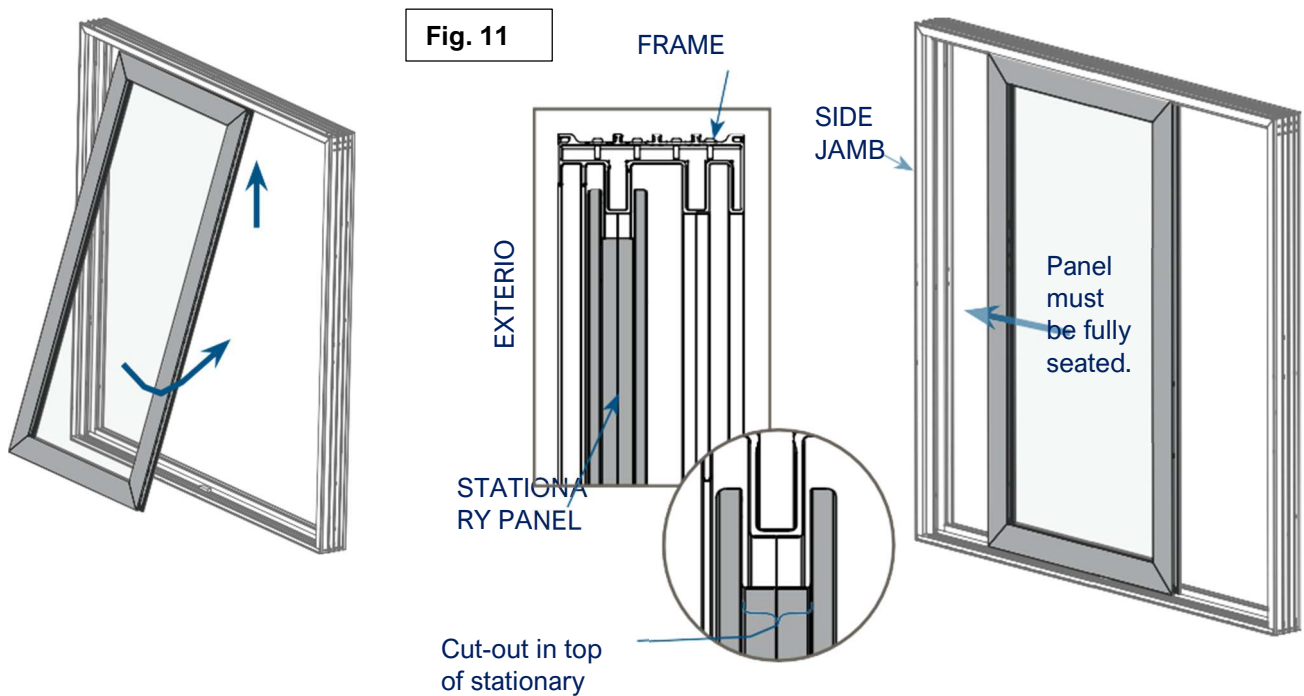

FIXED PANEL INSTALLATION OCCURS FROM THE EXTERIOR SIDE.

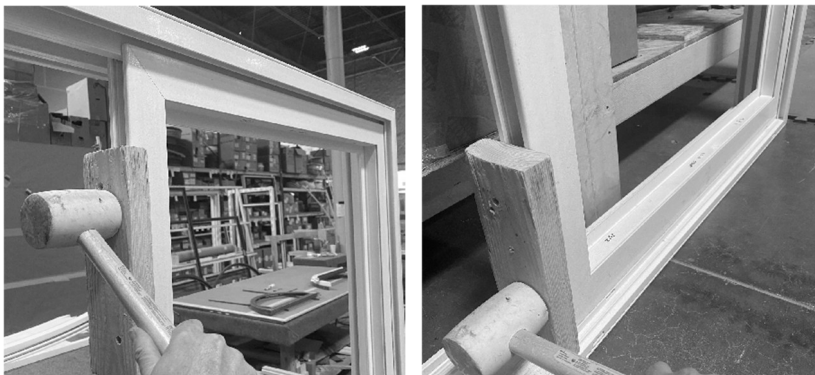

Pro Tip: Use a wooden block and rubber or plastic mallet to tap the Fixed Panel into place to ensure it is fully seated into the jamb.

B. ANCHOR THE FIXED PANEL (TOP)

1) Secure the Fixed Panel in place by installing the **Fixed Panel L-Brackets**

Ensure that both top and bottom L-brackets are centered and aligned with the groove in the door frame track.

- 2) Insert the top L-shaped metal anchor as shown. Align with pre-drilled $\varnothing 1/8''$ pilot holes.
- 3) Secure the metal anchor to the frame using **one (1) #10 x 3/4''** Phillips pan head screw (provided).
- 4) Secure the metal anchor to the fixed panel using **one (1) #8 x 3/4''** Pan Head screws (provided).

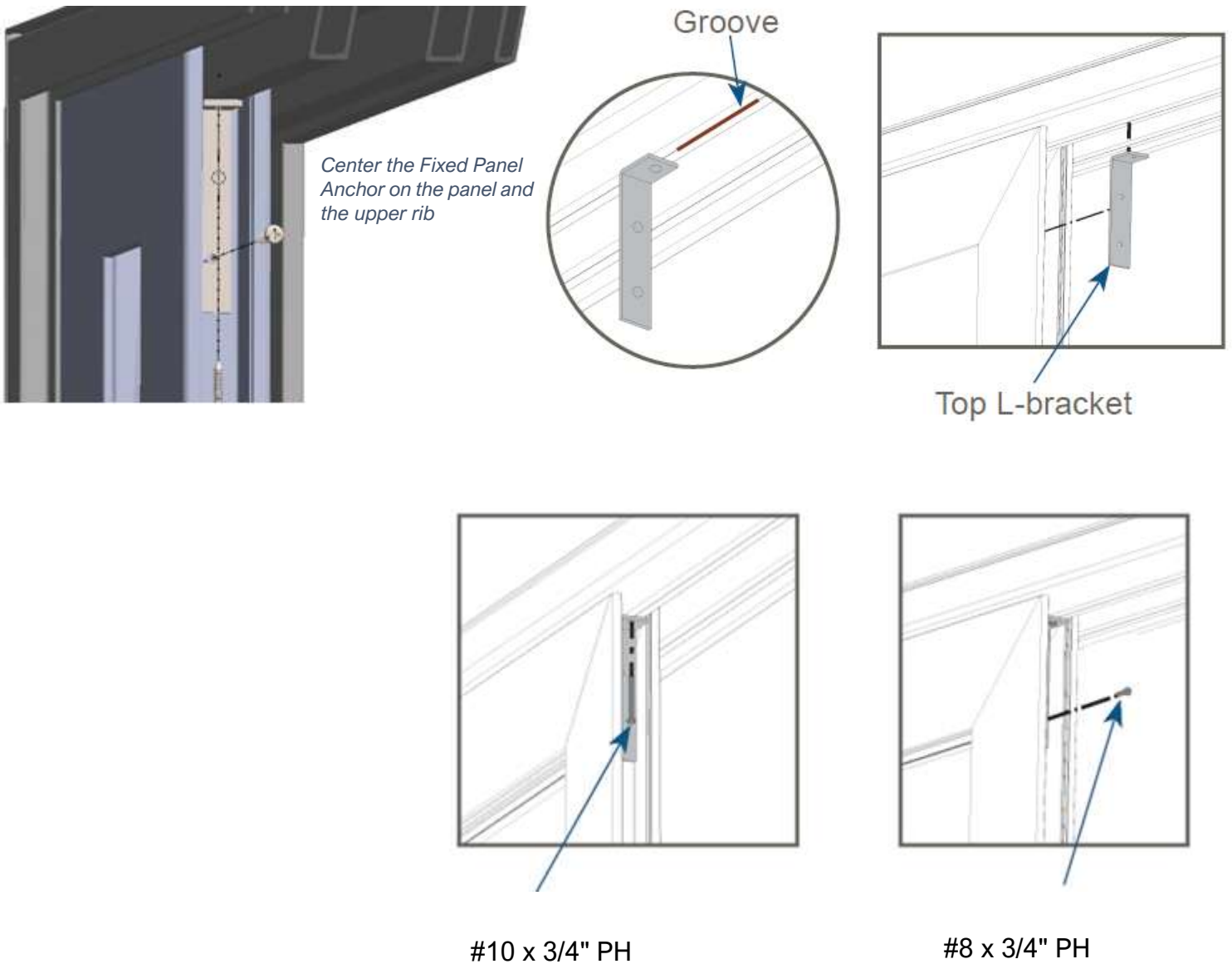

IT IS IMPORTANT THAT THE PANEL ANCHORS ARE EXACTLY CENTER ON PANEL AND FRAME!

C. ANCHOR THE FIXED PANEL (BOTTOM)

- 1) Insert the bottom metal anchor as shown.
- 2) Drill a 1/8" pilot hole in the sill portion of the frame and substrate.
- 3) Secure the metal anchor to the frame using **one (1) 10 x 3/4"** Phillips pan head screw (provided).
- 4) Secure the bottom anchor to the fixed panel using **one (1) 8 x 3/4"** Pan Head screws (provided).

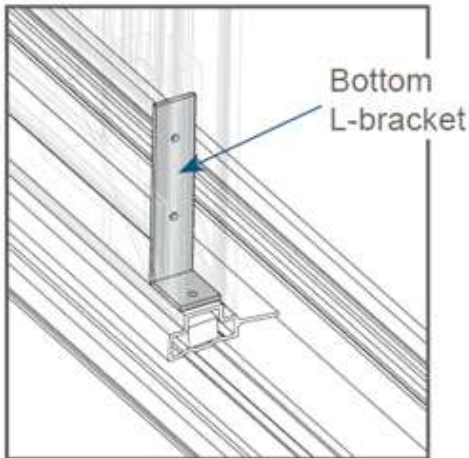

fixed panel hidden for easier viewing of bottom bracket

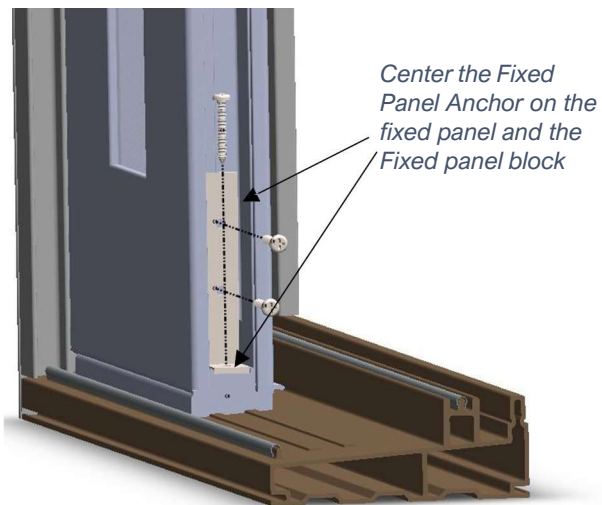
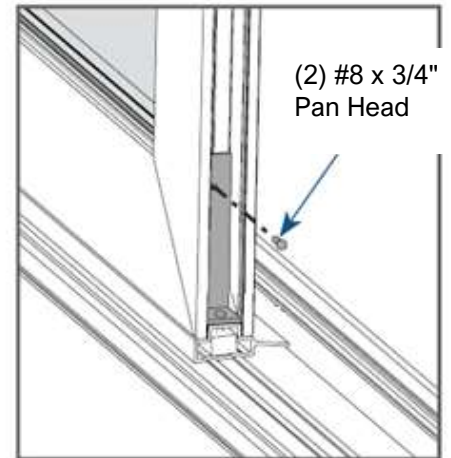
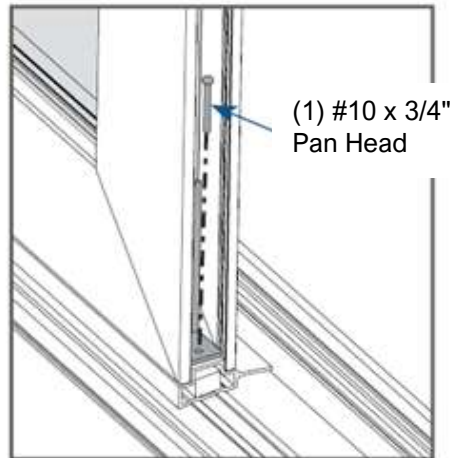

- 5) **Add color matching sealant to front edge of fixed panel to eliminate air leakage.**

6) PANEL INSTALLATION: 4 PANEL (OXXO) DOOR

A. Install Astragals

- 1) Check that Astragals have dust plugs installed at the top and bottom.
- 1) After anchoring the fixed panels on each end following Step 11, set the astragals tight into the exposed end of the installed fixed panel.
- 2) Locate factory-drilled clearance holes.
- 3) Use drill with extension and drill stop to drill \varnothing 1/8" pilot holes.

Do not drill deeper than 3/4"!

- 4) Install **four (4) #8 x 3/4"** Pan Head Screws (provided) into each astragal to pull it tight to the fixed panel.

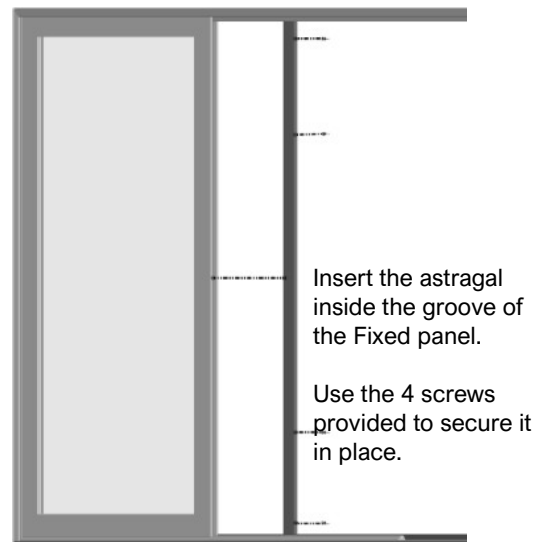

B. Install the Dust Plugs according to Step 14.

Following Step 14, install the Bottom Dust Plug using adhesive and slide-in the Top Dust Plug but **do not screw into it!**

C. Fixed Panel Interlock Covers according to Step 15.

Secure the Interlock Cover by screwing it into the Fixed Panel Fiberglass with the Interlock Cover Screws.

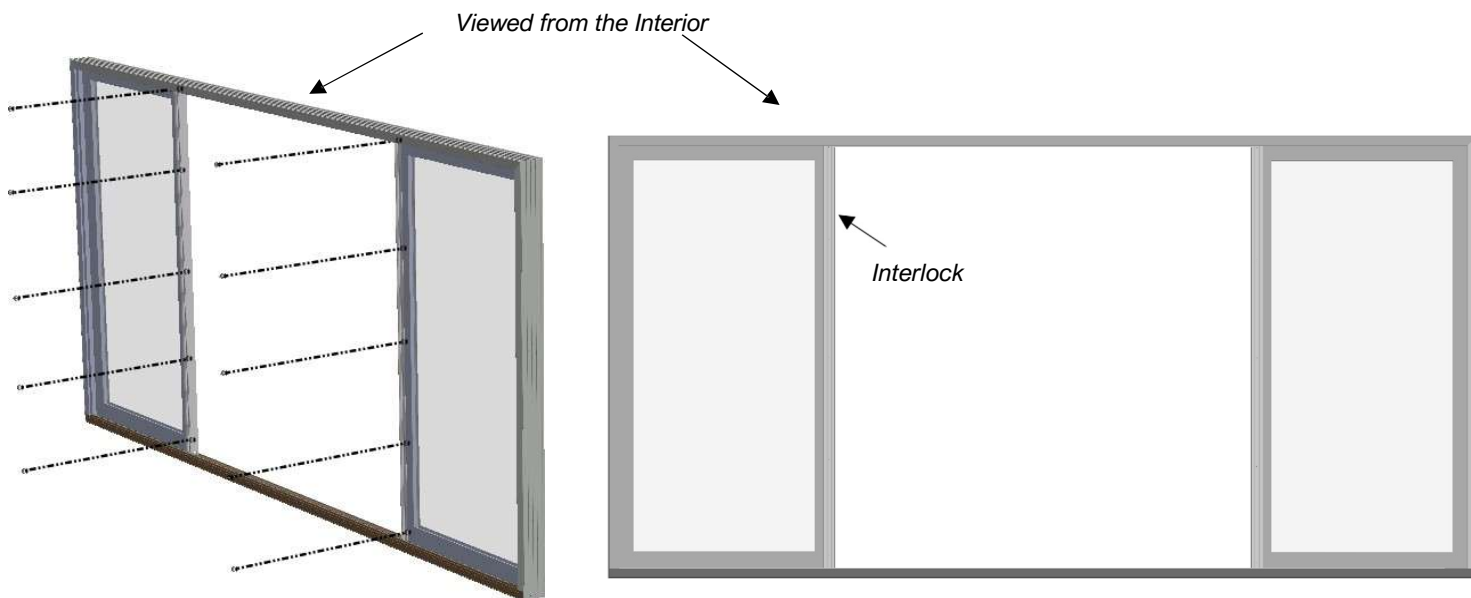

Interlock Cover on Fixed Panel Faces towards the Interior. For the Active Panel, it faces to the Exterior.

D. Install the Active Panels

Install the active panels from the interior side of the door by lifting it into the upper header and sliding the bottom onto the roller track. Insert the active panel in a central position along the width of the door. Apply the same steps for both active panels.

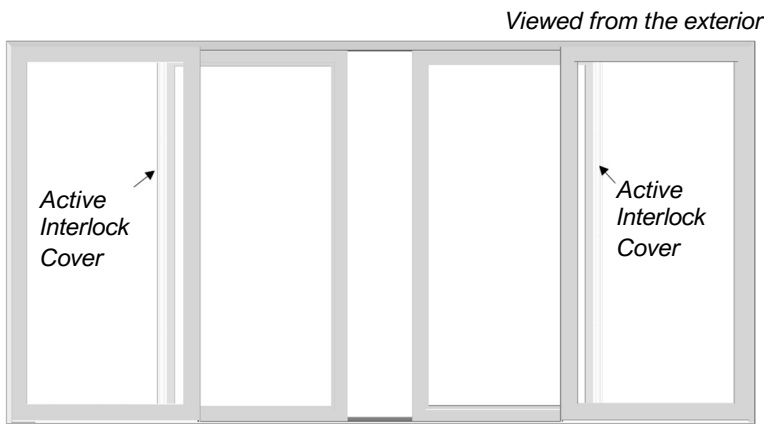
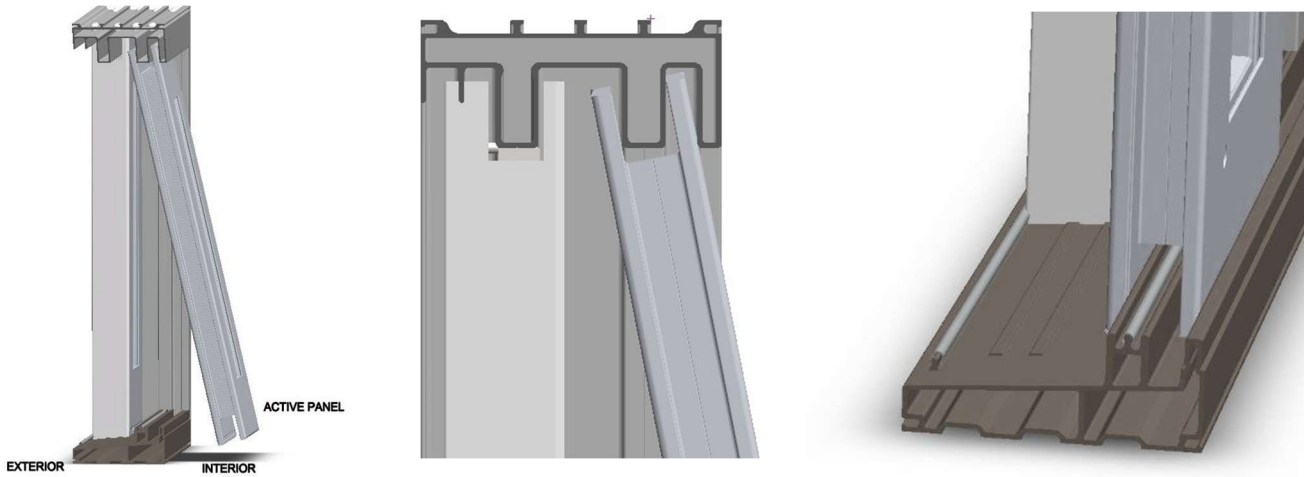

Remember:

Interlock Cover on the Active Panel must be installed before mounting the Active panel into the frame. Active Interlock Cover must be facing the exterior of the frame when installed.

E. Install Center Astragal

- 1) Insert the Astragal into the groove of **the Active Panel that does NOT have the locking mechanism.**
- 2) Screw the astragal to the Active Panel with the screws provided to secure it.

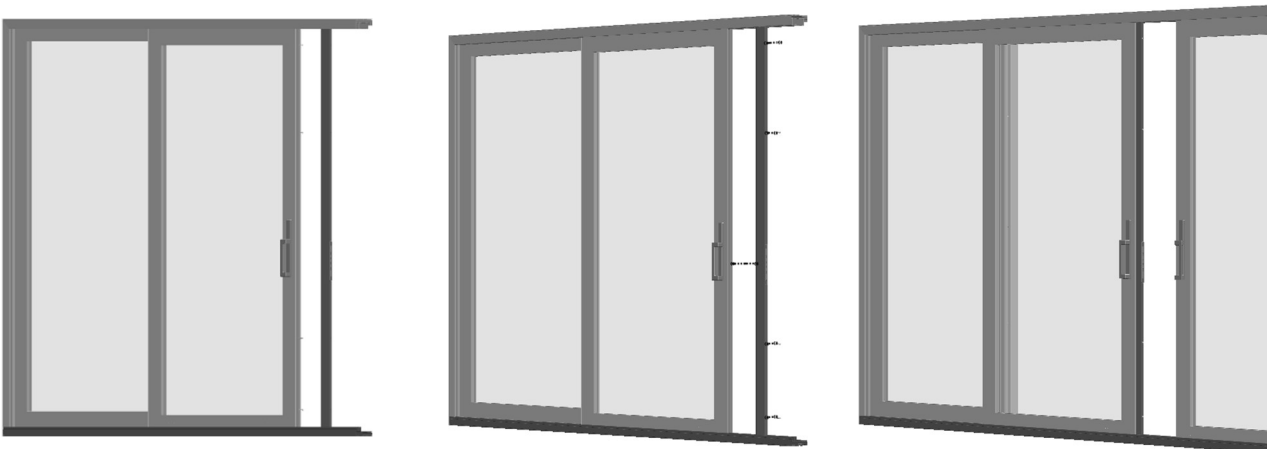

7)INSTALL DUST PLUGS

A. Bottom Dust Plug.

After securing the Fixed Panel in place and before the Fixed Panel Interlock is installed, locate the supplied Bottom Dust Plug.

- 1) Standing on the interior side of the door, identify the "Sill Riser-to-Fixed Panel Notch" where the Dust Plug will be installed.
- 2) Clean this area with alcohol and allow it to dry completely.
- 3) Install the Bottom Dust Plug by peeling off the adhesive cover and firmly pressing the Dust Plug into position flat on the door sill, between the Sill Track Riser and the Fixed Panel/Fixed Panel Riser at the open end (middle of door).

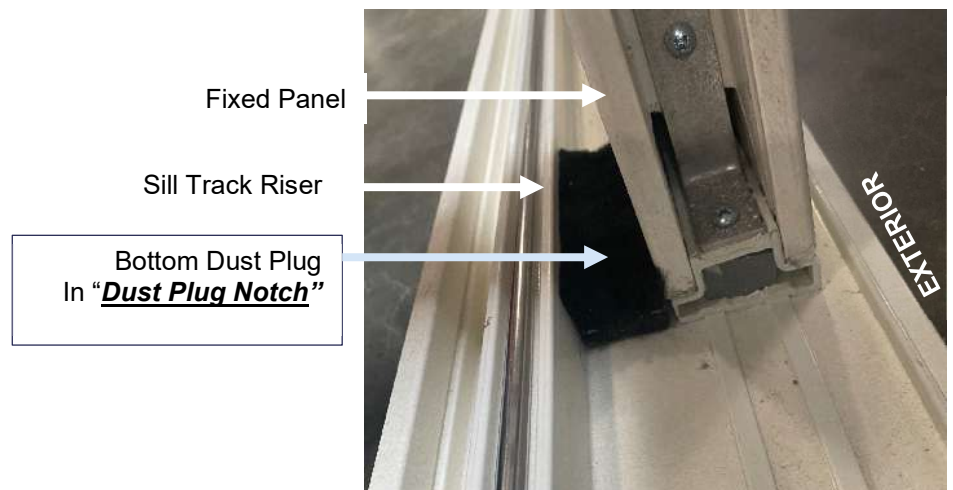

B. Top Dust Plug.

After securing the Fixed Panel in place and before the Fixed Panel Interlock is installed, insert the Top Dust Plug

- 1) Again, while standing on the interior side of the door, locate the Top Dust Plug position: it's the large center channel at the head, situated between the two raised elements that serve as panel guides.
- 2) Slide the Dust Plug into the channel, positioning it to the side of the Fixed Panel.

DO NOT SCREW IN THE DUST PLUG YET!

8) INSTALL THE FIXED PANEL INTERLOCK

A. Locate the two interlocks in the frame box.

- One is for the fixed panel (two for 4-Panel OXXO doors) ***This is the longer of the two interlocks.***
- One for the active panel (two for 4-Panel OXXO doors)

B. Snap in the Fixed Panel Interlock.

- 1) Standing on the **interior side** of the door, line up the fixed panel interlock with fixed panel so that it is flush with the top and bottom of the fixed panel.
 - The groove with the pre-drilled screw holes will face **towards you (Fig. 12)**
- 2) Insert barb (**Fig. 13**) on exterior side of interlock into the groove on the fixed panel and tap into place.
 - Use block of wood or rubber mallet to avoid damage to the parts.
 - Start at the top and carefully tap the interlock into the stile grooves.
 - Stop halfway down the interlock.
 - Do the same starting at the bottom, working up towards the center of the interlock.

C. Secure to the fixed panel from the interior side of the unit using (4) #8 x 3/4" Pan Head Fixed Panel Interlock Screws.

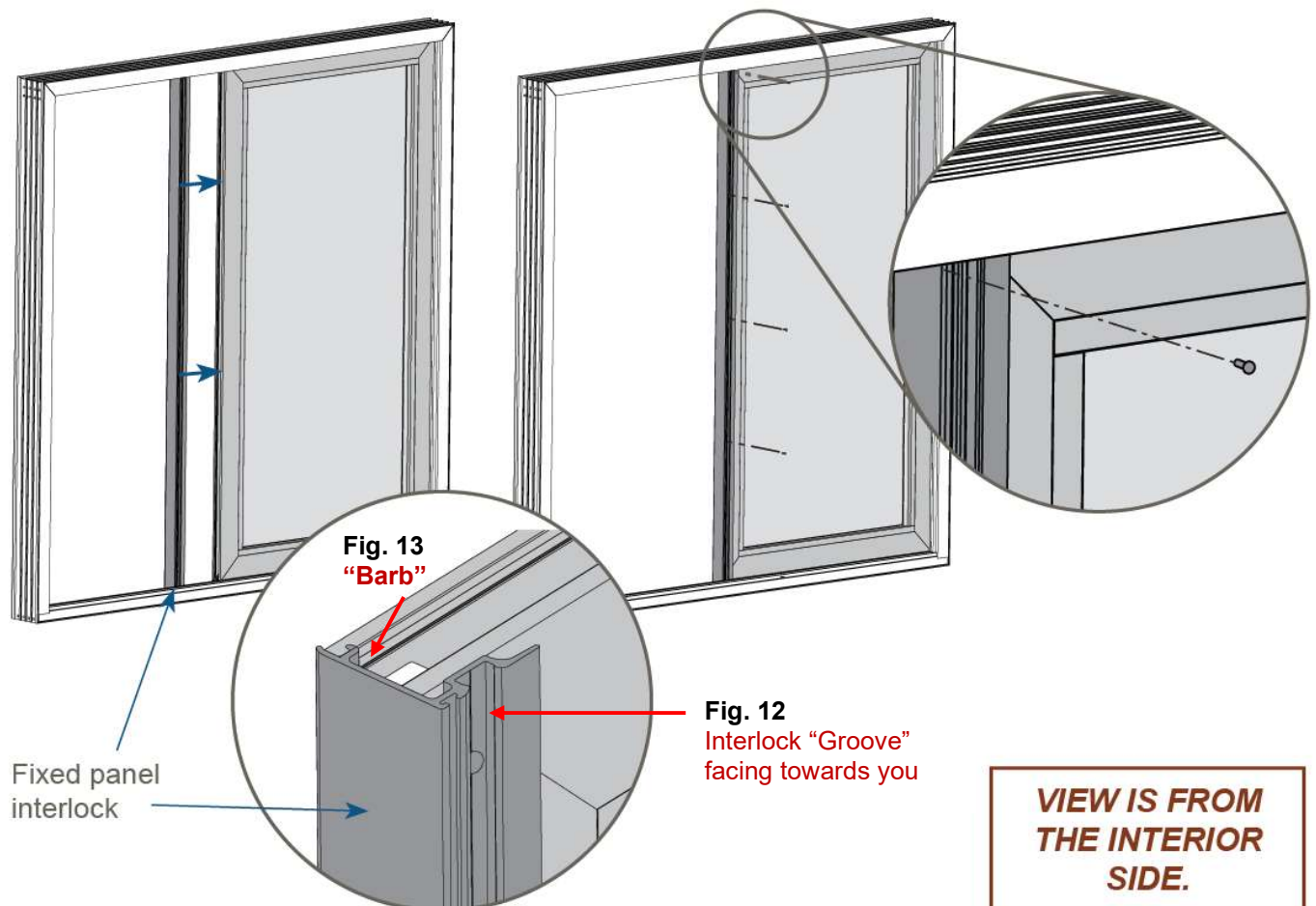

9) INSTALL THE ACTIVE PANEL

TOOLS NEEDED: GLASS CUP

IMPORTANT: ENSURE THE ROLLER WHEELS ARE FULLY RETRACTED PRIOR TO INSTALLATION.
ROLLER WHEELS ARE SHIPPED IN THE RETRACTED POSITION.

IMPORTANT: THE ACTIVE PANEL MUST HAVE THE INTERLOCK COVER APPLIED BEFORE THE PANEL IS SET IN PLACE.
*INTERLOCK SCREWS ARE NOT ACCESSIBLE AFTER THE PANEL IS SET IN PLACE.
(NEW DOORS / DOOR PANELS WILL BE SHIPPED WITH INTERLOCKS FACTORY-APPLIED)*

A. Install the Active Panel

- 1) Using a Glass Cup, carefully lift the active panel up into the top portion of the installed door frame, and gently set it down onto the roller track.
- 2) Ensure the cut out in the top of the panel seats around the track in the frame. (**Fig. 14**)
 - It is easiest to insert the active panel when it is in a central position (middle of the frame).
- 3) Slide the active panel over into the side jamb of the door frame.
 - Ensure the active and sliding panel interlocks properly meet when the active panel is in the closed position.

**ACTIVE PANEL INSTALLATION
OCCURS FROM THE INTERIOR**

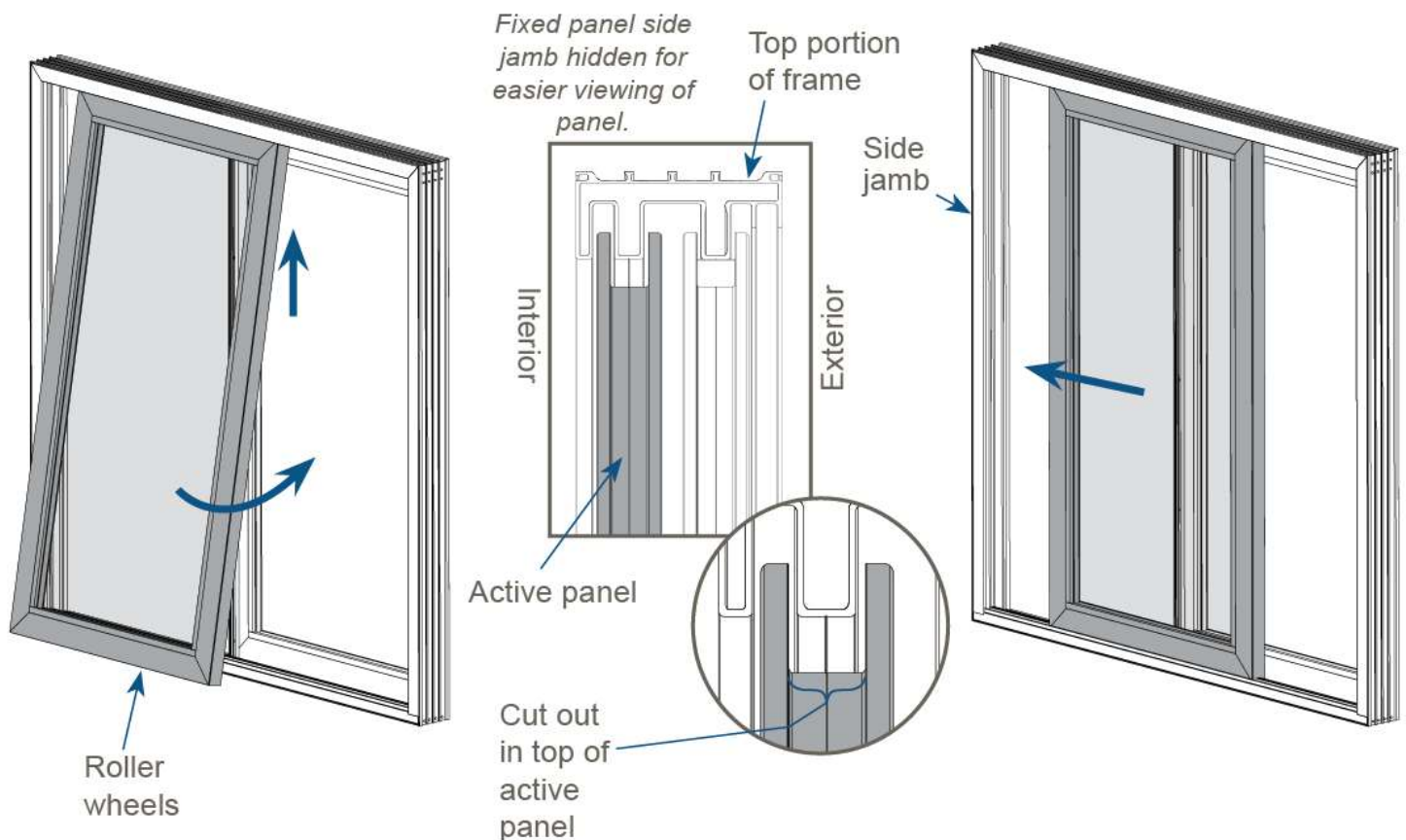

10)FASTEN TOP DUST PLUG

- A. Slide the Dust Plug to the center of the interlock rails, positioning it 1-1/4" from the end of the Active Panel.
- B. Secure the Dust Plug with (2) black #8 self-tapping screws.

Note: This position interferes with the removal and reinstallation of the Active Panel. To remove the Active Panel, the Dust Plug must be repositioned to sit beside the Fixed Panel.



11)ADJUST PANEL ROLLERS

**THIS STEP REQUIRES AT LEAST TWO PEOPLE OR
A 1-PERSON OPERATED VACUUM-LIFT WITH GLASS CUPS**

TOOLS REQUIRED: GLASS CUPS, PHILLIPS-HEAD SCREWDRIVER

- A. **Lift the Panel:** Use a Glass Cup to lift the panel: Ensure the weight is off the rollers before adjusting.

Warning: Adjusting the active panel with weight on the rollers may strip the adjustment screws.

Never use an impact driver or power drill.

- B. **Lower the Rollers:**

While holding the panel up, lower the rollers (raising the panel) by adjusting the interior side screws with a hand screwdriver. Test door operation and continue adjusting the roller screws until the Active Panel is plumb and slides smoothly.

Warning: Failure to properly adjust the Active Door Panel after installation may damage the frame or sash and impact lock functionality.

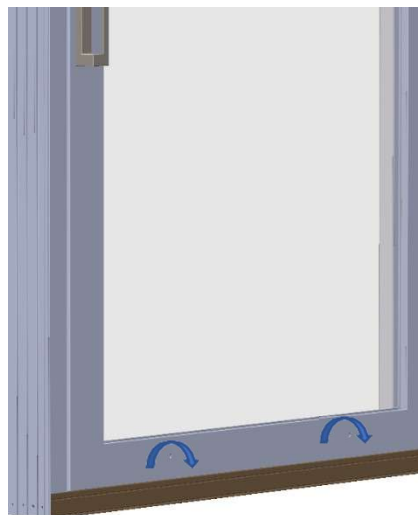

12)INSTALL HEAD STOP BUMPER

A. Insert the head stop bumper into the center channel of the head jamb where the Fixed Panel is located.

- Seat stop bumper flush with head jamb and tight to the is.

B. Secure with one (1) #10 x 1" Pan Head self-tapping screw.

***NEVER ADJUST THE ROLLERS
WITH AN IMPACT DRIVER OR
POWER DRILL***

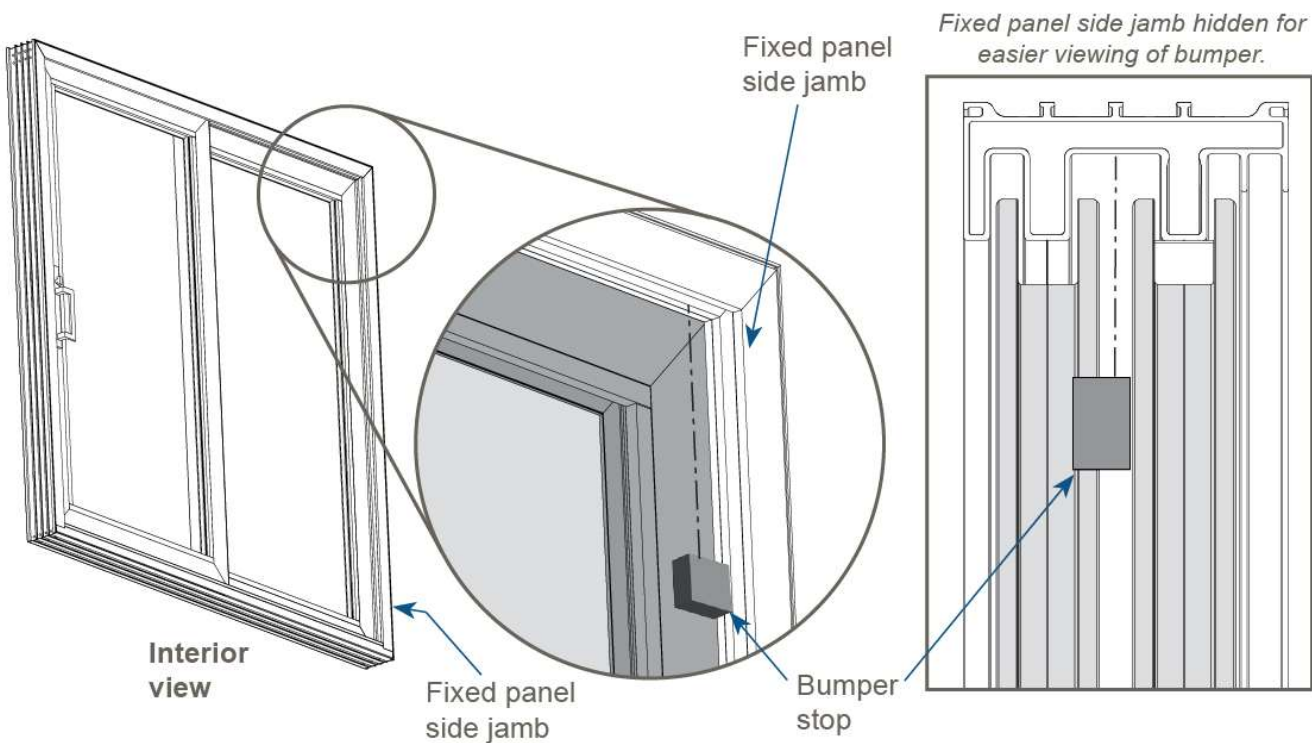

13)INSTALL THE HANDLES AND CHECK/ADJUST LOCKS

A. Attach handle to the escutcheon plate using (2) machine screws (provided in box). Take care to pay attention to door handing:

- The curve of the handles should slope toward the center of the door.

B. Install the handles according to the manufacturer’s instructions

C. Tighten securely to prevent loosening during operation.

CAUTION: DO NOT OVERTIGHTEN HANDLE SCREWS.

OVERTIGHTENED HANDLE SCREWS WILL COLLAPSE THE PANEL CAVITY AND RESULT IN COLLISION WITH THE FRAME ACTIVE JAMB

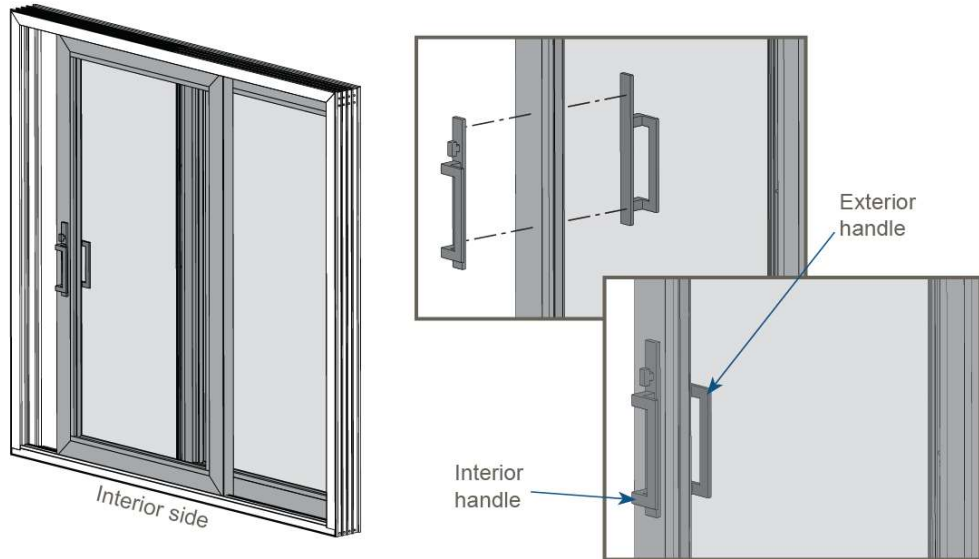

D. Test the lock functionality and adjust as necessary to ensure smooth operation and secure locking.

- Adjust the keeper height as necessary by loosening the keeper screws and repositioning the keeper.
- The lock strikers (throws/latches) can be adjusted by turning the slotted adjustment screw on the face of the mortise lock striker (throw/latch).

E. Confirm that all components are properly aligned and make final adjustments to the locks if needed.

14) SECURE KEEPER: GRANDLINE 4-PANEL (OXXO):

The keeper is factory-installed with two screws that can be loosened to allow adjustment. After the keeper is correctly located so that the locks operate smoothly, the keeper must be secured in place.

- A. Use (2) #10 x 1 Pan Head Screws (provided) and install them into the holes at the top and bottom of the keeper

15) INSTALLING THE INSECT SCREEN

- A. Mount the screen door on the outer track of the patio door. The top of the screen door will be inserted in the outer groove of the header.

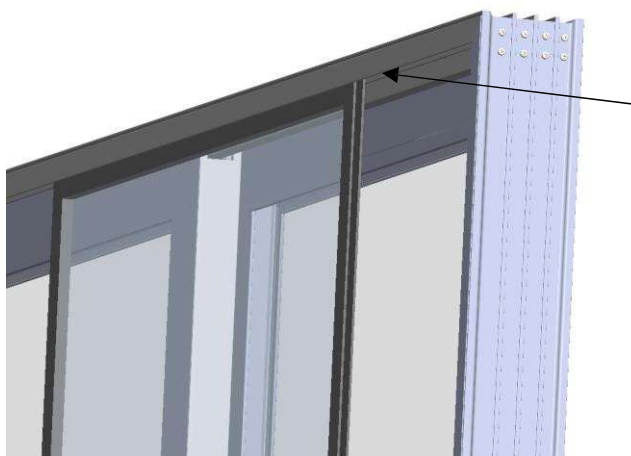

The top of the roller screen will be inserted on the outer groove of the header.

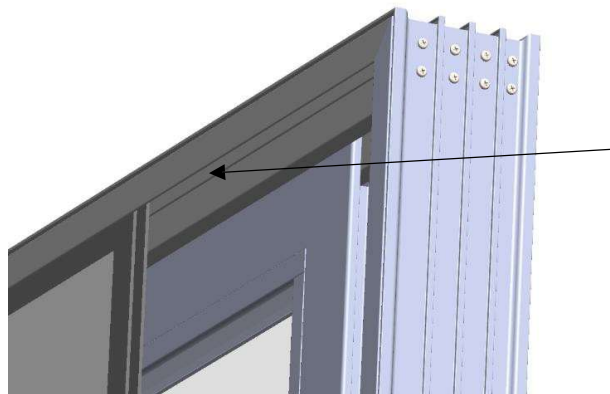

Outer groove where the roller track gets inserted.

Mount the roller screen on the outer track of the sill.

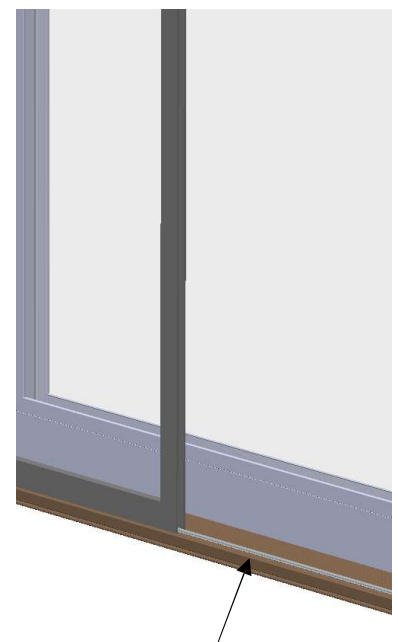

16) FINAL CHECK FOR SQUARE AND DOOR OPERATION

Doors should NEVER be load bearing or contribute to the structural integrity of the building in any way after installation

A. Final Check for Square:

1. Measure both diagonal distances on the interior of the door. These two lengths must be within 1/16" (2mm) of each other.
2. The height of the frame at the center must be the same as the height at each end.
3. The width of the frame at the center must be the same as the width on each end.

B. Final Door Operation Check:

Final Adjustment of Rollers After Load Testing, after adjustments, simulate typical door use by opening and closing it multiple times to confirm smooth movement, proper locking, and alignment. Check that the rollers and track remain free of binding or sticking.

- Ensure there's no movement or flex in the frame under operational load, as this could indicate a need for further adjustment.

C. Regular Maintenance Tip for Users:

Regularly clean out debris from tracks, weep holes, and seals. Dirt and debris buildup can hinder door operation and affect drainage over time.

- Ensure there's no movement or flex in the frame under operational load, as this could indicate a need for further adjustment.

D. Documentation and User Instructions:

E. Provide the user with documentation on the final measurements for square, level, and plumb.

- Include maintenance instructions, specifically emphasizing regular track, roller, and weep hole cleaning to ensure optimal operation.
- Provide the user with a quick "Door 101" on basic operations — locking, unlocking, rolling, and footlocks — plus a hands-on demo for re-installing the sliding screen. (Because let's face it, someone will eventually plow through it like it's not even there!)

17) COMPLETE FLASHING

A. Inspect all flashing and fasteners to ensure there is no damage to the water seal. Notes:

- Only fully adhering flexible flashing shall be used and must meet AAMA 711
- Sealant must meet ASTM C920

B. (Exterior side) Install Drip Cap across door head (Fig. 18) and flash over it with head flashing (Fig 19).

C. Integrate all flashing with building's Weather Resistant Barrier (WRB) system (Fig.20) per WRB manufacturer's instructions.

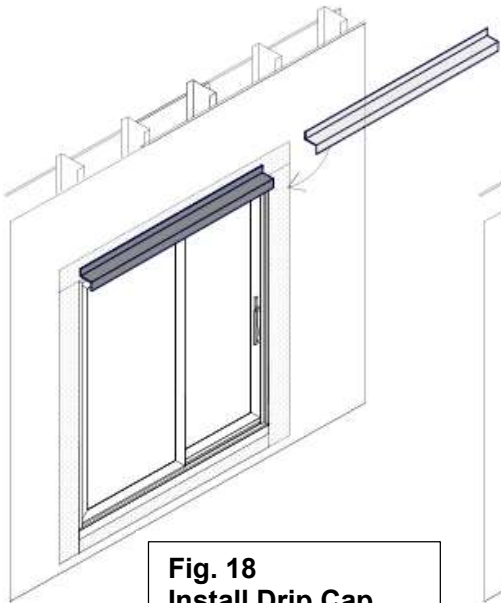

Fig. 18
Install Drip Cap

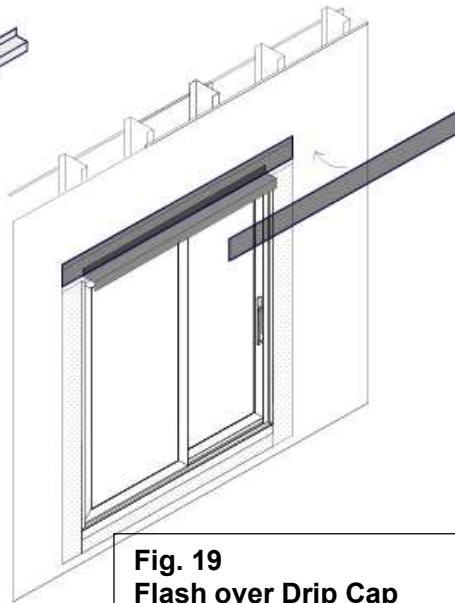

Fig. 19
Flash over Drip Cap

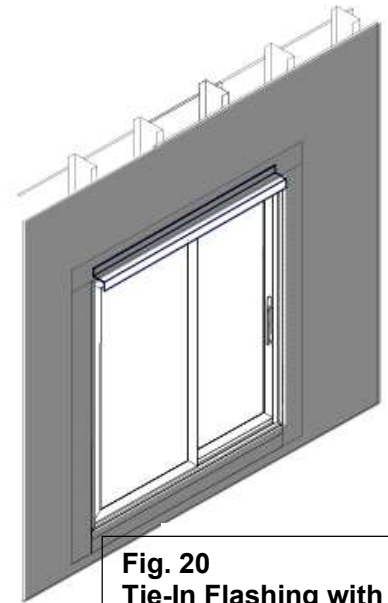

Fig. 20
Tie-In Flashing with
Building's WRB

D. (Interior side) Install Air Seal: Insert backer rod between the door frame and the rough opening, using a rod approximately 35% larger than the gap width. Apply air-tight sealant over the backer rod, filling the cavity to seal the joint between the door and the rough opening. Form fillet joint that extends up onto face of door frame and across face of rough opening flashing to connect these elements.

- **Use Low-Expansion Foam Sparingly:** Choose low-expansion foam specifically made for windows and doors. Too much foam or high-expansion types can distort the frame alignment.



PRO TIP:

Remember that *interior* air-tight joints offer the best protection against wind-driven rain. Exterior joints are only secondary in moisture defense.

Image Source: Prosoco AirDam

18) FINISHING UP

- A. Allow Sealant to Cure Fully:** Avoid disturbing the door system or subjecting it to movement or stress until the sealant has cured. This ensures a strong, durable seal.
- B. Inspect All Gaskets and Seals:** Ensure that all door gaskets and weather seals are securely in place and undamaged, providing a continuous weather barrier.
- C. Check Weep Hole Covers:** Ensure that weep hole covers are securely in place on the exterior side of the sill.
- D. Double-Check Weep Holes / Drainage:** Before sealing or flashing, confirm that weep holes are clear of debris. Blocked weep holes can cause water to pool and damage the door system over time.
- E. Re-Install Screw Hole Plugs in Frame:** Apply sealant to the screw hole plugs removed during frame installation, then insert them back into the clearance holes.
- F. Add color matching sealant or Mull Strips to accessory groove to ensure it is fully covered**
- G. Install Roller Adjustment Hole Plugs:** Locate roller adjustment hole plugs and insert them into the holes on the Active Panel(s).
- H. Final Clean-Up:** Clean all surfaces around the door, removing any adhesive residue, fingerprints, or dust. This gives a polished look and ensures no residue interferes with sealant adhesion.



Pro Tips:

Apply protective sheeting or masking over panels, glass, and frame during construction activities like painting, power washing, grinding and welding metals.



Protect the sill and sill roller track with cardboard if the door remains open during construction activities.