

INSTALLATION GUIDELINES: ZENITH SERIES using perimeter Anchor Straps (new construction or replacement)

Wall systems designed to manage water or that have been upgraded to manage water are important for a trouble free installation. Site conditions, building designs, building materials and construction methods vary from project to project. Determining the proper installation is the responsibility of you, your architect or construction professional. Installation will require a minimum of two (2) or more people depending on the size/weight of the windows, size of the project and schedule.

1. INSPECTION:

Customer should conduct a thorough inspection of the window products after receiving them. Windows should be inspected for proper type, operability, shipping damage, and size. ***All damages or freight claims must be reported within 48 hours of receipt and submitted in writing within 5 business days of receipt to; service@thinkalpen.com.*** Follow these steps when inspecting new window products:

Thoroughly inspect the windows, note that some products contain items that are not to be removed until after the windows are installed properly.

Lock all sashes opened during inspection prior to installation.

Check for proper size and location prior to the start of installation.

2. STORAGE AND HANDLING:

Alpen HPP does not recommend storing windows prior to installation, but if necessary windows should be properly stored when installation will not take place immediately. The following recommendations will help you store and protect the products until installation can begin:

Windows shall be transported in an upright position with all manufacturers' packaging in place. Then stored or staged in an upright position, sitting on the sill, as close to 90 degrees as possible. Keep windows away from moisture and off the ground. ***Do not lay flat, transport flat or carry flat.***

Installers should wear clean gloves when handling products.

Do not rack, twist, drag or pull window frames.

All windows shall be stored in the upright position as close to 90 degrees as possible and placed on their sills.

If packaging is removed, store with non-abrasive separators between frames.

Handle units with shipping handles or glass cups during installation as much as possible. Use appropriate manpower when lifting large units.

Windows shall be stored out of the weather in a clean, dry, low-traffic area, away from direct sun light, extreme temperatures and temperature changes. Do not leave wrapped windows exposed to weather, sunlight or heat. Do not store windows in containers, trailers, or areas that might undergo dramatic fluctuations in temperature and humidity, or is also used for storage of hazardous or chemical materials. Off-gassing of these materials may degrade the window finish or seals.

If windows must be stacked so some lean against others, always stack the largest units at the back in a completely upright position and proceed forward with gradually smaller units. **Never lean units larger than 40" tall.**

3. RESERVOIR REMOVAL INSTRUCTIONS:

- a. Once units have arrived at the jobsite, allow them to acclimate to their openings/jobsite conditions for a minimum of 24 hours if possible. Larger units may take up to 72 hours.
- b. Once acclimated, the capillary tube requires crimping in three places, and reservoir removal. Crimping should be performed between 12 and 3 PM, or when the temperature is at the expected seasonal average. Ensure the glass panes are flat before crimping.

- c. Crimp (hard enough to collapse or flatten the tube) the capillary tube ¼" from the edge of glass/glazing bead, again at ¼", and again at another ¼". Use the flat jaws of a pair of pliers (shown).

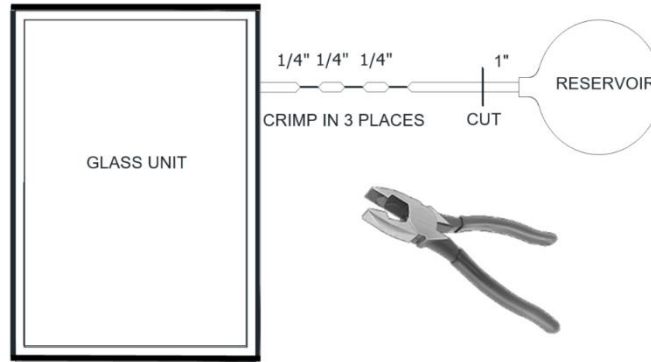

- d. Cut the tube 1" from the end. Remove the reservoir and then dip the cut end in a sealant that adheres to steel. Let sealant dry.
- e. Tuck the capillary tube under/behind the glazing bead using a plastic putty knife or tape to the edge of the IGU for "Glass Only" products.
- f. Please reference "Breather Tube Tucking Instructions" or call your Sales Representative for more information.

4. PREPARE WINDOW OPENING:

- a. Verify the opening is level and square. Verify the window will fit the opening. Allow ¼" (+/- 6mm) space between window frame and rough opening at the jambs for shimming and adjustment (1/2" minimum overall in width). Minimum R.O. allowance is 1/2" overall in height. This allows for shim space at the bottom of the window (use enough shims to fully support the window and insure sill remains straight) and the remaining space at the top of the window to allow for movement of the header above the window.
 Shim space may be larger depending on project-specific installation requirements and insulation requirements. Measure width and height at several points along span to ensure dimensions are uniform and no bowing or warping exists. (Shim window at the sill and jambs, not at the head.)

b. Perimeter Blocking:

- i. Stud walls: No additional blocking is required in wood-framed/stud wall openings. Make allowance for positive flow for moisture to the exterior at the sill. Cover with sill pan, flashing or self-adhering flexible flashing. (Shims at sill and jambs are recommended.)
- ii. Masonry walls: Pretreated perimeter blocking can be installed or a pretreated or hardy board wedge at the sill can be used for positive water flow to the exterior. Cover sill with sill pan, flashing or self-adhering flexible flashing. (Shims at sill and jambs are recommended.)

5. SILL FLASHING & DRAINAGE:

Ensure window opening is flashed and sloped to allow for water to drain to exterior. Review window position in the opening with relation to the water plane of the building. Follow regional best practice guidelines or AAMA Installation Masters guidelines to select and install sill flashing type and installation procedures according to site-specific climate/weather and wall conditions.

- a. Sloped Sill- many brick and CMU wall constructions utilize a sloped masonry sill to drain water away from the window; in this case, the window typically rests on top of shims, on flashing, on the masonry sill and is sealed with a continuous bead of sealant on interior on the flashing back dam and discontinuous sealant on exterior to allow for moisture migration. (Sill flashing at the sill is always the best practice.)

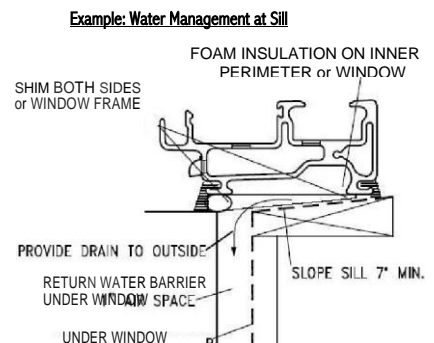

Sill Pan or sill flashing- in cases where a masonry veneer or other exterior finishes are applied to a wall assembly, the drainage plane is typically located in a "through-wall" cavity behind the veneer. In this application, window sill flashing (flexible, self-adhesive or pre-formed sill pans) must be integrated into the existing drainage plane.

**Please refer to Installation Masters for information regarding back dam heights, side jamb heights for flashing, redundant lines of sealant, and flashing in weatherboard fashion.

6. SET SHIMS:

Use 1/8" thick minimum non-compressible, impervious shims. Thicker shims may be required depending on window rough opening but should not exceed 1/4". Shims should be wide and long enough to fully support the window frame.

Place shims every 6-8" along window sill and within 3" of corners, sides, and mull joints. Ensure adequate and level support of window frame is achieved.

Note: Improper placement or insufficient number of shims may disrupt performance and operating capabilities.

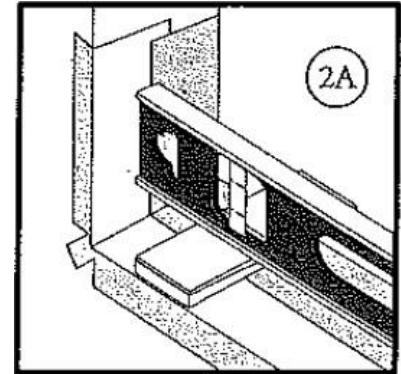

---SEE SHIM & CROSS-BLOCKING DIAGRAM BELOW---

SHIM & CROSS-BLOCKING LOCATIONS

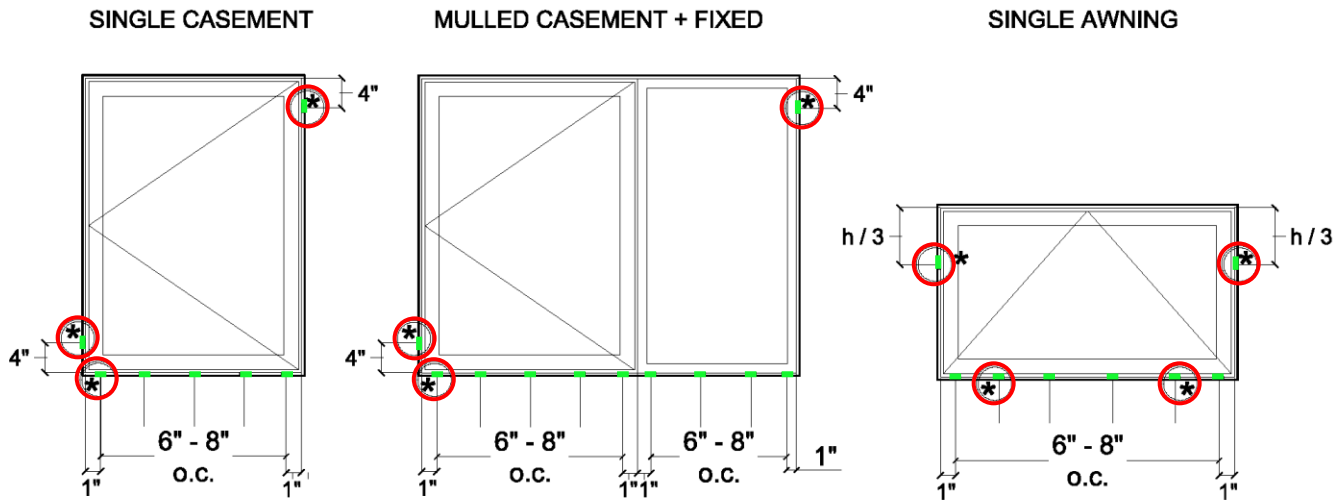

— SHIM - 1-1/2" wide x depth of frame
(type horseshoe or tapered shim, plastic or other non-compressive material)

 IMPORTANT CROSS-BLOCKING LOCATION

7. ANCHORING METHOD

Window frames should be set plumb, level, square and secured to surrounding structure. Window anchorage must be sufficient to meet structural requirements of local building codes.

- a. Snap-on Strap Anchor (B) – Attach strap anchors on window(s). (Location and spacing below) Foam may need to be removed so the strap will snap onto the frame. Shim at anchor strap locations at jambs. (Straps with four holes are for Casement, Picture, Awnings and two holes are for Double-hung, Single-hung and Horizontal Slider) Secure with at least 2 fasteners per anchor strap.

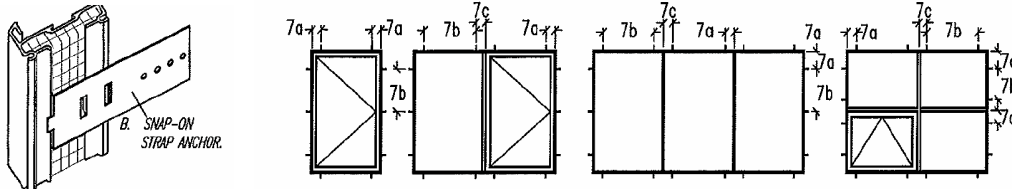

- b. Recommended anchor locations:

- 7a. Strap anchors – (a) Secure within 4” from the corners
- 7b. Perimeter Strap Anchors – (b) Spacing should be 12-16” on-center (no greater than 16” o.c.)
- 7c. Mullion Strap Anchors points– (c) Always anchor within 4” from mullion. For wind zone areas, you can increase to two straps on each side of the mullion.

8. SETTING THE WINDOW

Carefully lift the window into place. Insure frames are set plumb, level and square by checking the frame horizontals and verticals with a level and the diagonal measurements with a tape measure. Secure to surrounding structure using the Strap Anchor method described above.

- a. Anchor Straps – Set window onto shims so that the frame is fully supported and secure windows by fastening through straps placed at locations/spacing noted in “Strap Anchor Locations” above. Straps may be cut to size or bent around framing to fit jamb/sill/head depth.
 - i. When used in combination with sill flashing:
 - 1) Notch flashing back dam where it interferes with anchor straps, prior to installation.
 - 2) Seal window to back-dam and secure using anchor straps
 - 3) Apply continuous bead of sealant beneath and over anchor straps crossing notches in pan flashing to provide complete air & water barrier along entire interior edge of frame.
 - ii. Sills and trim – sill trim may need to be carved out where crossing anchor strap locations to allow trim to sit flush to rough opening, or wood spacers may be set between straps to create level surface for trim or interior sill installation.
- b. Option to anchor straps at sill. (DH, SH or HS details shown)
 - i. Pretreated 1-1/2” x 4” x 1/2” wood blocks sized to slide into the open back of the sill pultrusion can be fastened at the sill prior to setting the window. Care should be taken to place the blocks for correct placement in the opening. Seal between the block and sill flashing and also to seal and tool the head of the fastener. After setting the window, follow anchor strap installation on the head and jambs. Discontinuous sealant at the front of the window and backer rod and sealant or back dam at the interior.

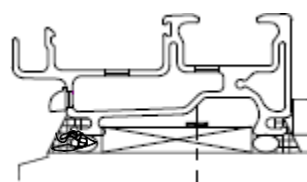

Double-hung example

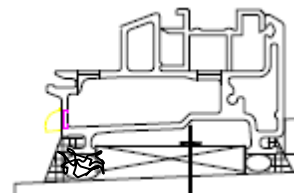

Single-hung example



8. DRIP CAP (provided by others)

Integrate window with existing drainage plane at head and jambs. Ensure drip cap at window head is in place and effectively sheds water beyond window frame. Water should not be drained down exterior surface of window frame or glass. Failure to provide adequate head flashing/drip cap may void warranty.

9. SEAL EXTERIOR PERIMETER

Use backer rod and sealant to create a seal at head and jambs to ensure tight water & air resistance. (Insulate cavity between exterior and interior seals described below.) Apply discontinuous caulking at sill on exterior to promote water migration to exterior.

10. INSULATE JAMB AND HEAD CAVITIES

Fill cavities at the jambs and head between window frames and rough opening (R.O.) with polyurethane low expansion foam, closed cell foam or loosely filled with fiberglass batt insulation. Do not distort frame by over packing. A well filled cavity improves thermal performance.

11. SEAL INTERIOR PERIMETER

Use backer rod and sealant to create an interior seal that will promote continuity of vapor barrier to reduce risk of condensation within the cavity. Well-sealed window perimeter will ensure windows will meet advertised water & air resistance. (It is important to have exterior and interior sealant for the best performance.)

12. ALTERATIONS

Windows should never be load bearing after installation. Window should not be modified to accommodate air conditioners, exhaust fans, etc.

Recommended resource for effective water management building details per climate type: “*Builder’s Guide*” Series by The Building Science Corporation (Building Science Press, 2006 & 2009)

Installation Instructions for Structural Mullion:

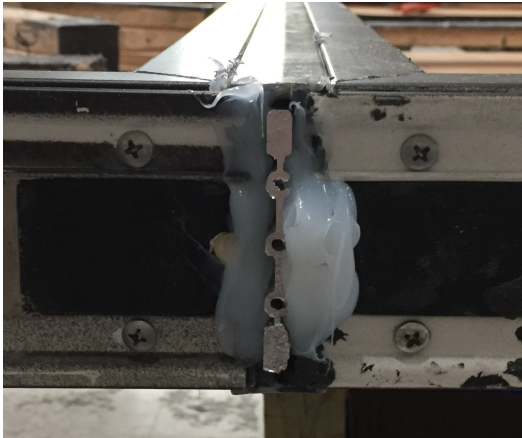

Two 4" aluminum reinforcements are inserted into the mullion at Alpen's factory.



Windows will be packaged with two 6" aluminum plates that serve as mullion anchors. Plate may be turned to interior or exterior depending on application.

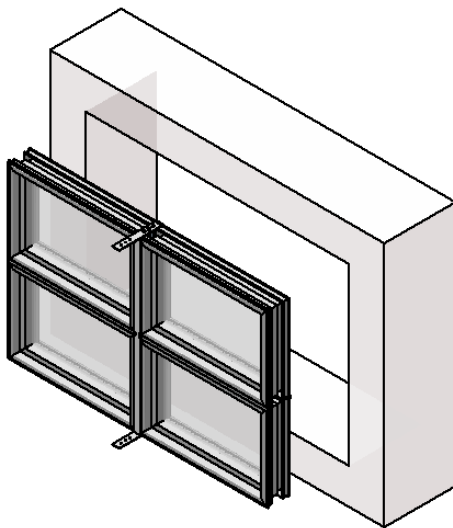

Before installing the window, fasten the two 6" mullion anchor plates to factory-installed 4" aluminum reinforcements (above) on top and bottom of the window.

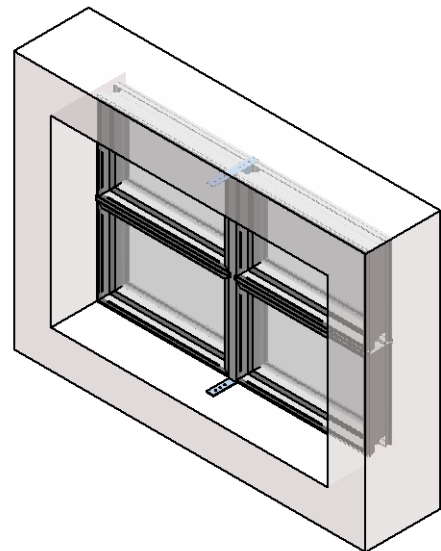

After the window is installed, fasten through nailing fin or anchor brackets to secure window in opening, then fasten mullion anchors to rough opening to secure mullion assembly to framing. This connection serves to transfer wind load on the assembly to framing.